

Film-Tech

The information contained in this Adobe Acrobat pdf file is provided at your own risk and good judgment.

These manuals are designed to facilitate the exchange of information related to cinema projection and film handling, with no warranties nor obligations from the authors, for qualified field service engineers.

If you are not a qualified technician, please make no adjustments to anything you may read about in these Adobe manual downloads

www.film-tech.com



Technical Achievement Award

To Dr. Leo Catozzo

For the design and development of the CIR-Catozzo
Self-Perforating Adhesive Tape Film Splicer.

“ The Catozzo Splicer has greatly
assisted the craft of film editing.
Incorporating the use of
self perforating adhesive tape,
the picture, dialogue and music
can be cut, divided, joined,
unjoined and rejoined without
losing a single frame of film “

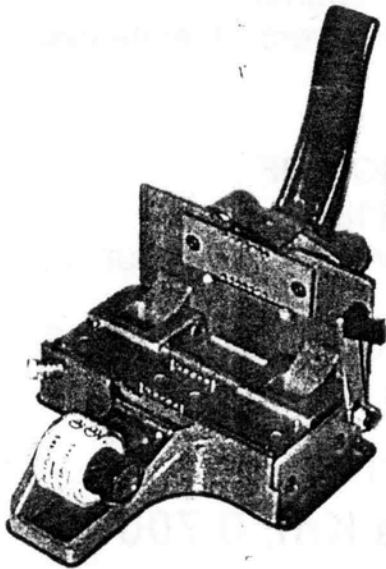

Splicer for
35mm
cinematographic film

M3-35mm (for picture only)
M3-35mm 2T (for picture & magnetic)

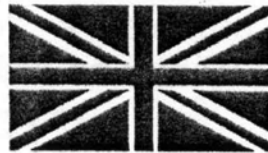

INSTRUCTIONS FOR USE

before operating the unit please
read this manual thoroughly and
retain it for future reference

ATTENTION:

For a correct use and to avoid injures to the operator, place the splicer on a flat, stable surface when operating.

Before using the splicer, make sure:

- 1) that the adhesive tape (S fig 1) , three or four superimposed layers, is applied to the matrix. It ensures that the little rectangles cut off by the perforators remain under the matrix and do not turn up sticking to the film.

NEVER TAKE IT OFF, BUT RENEW IT FROM TIME TO TIME !

- 2) that the adhesive tape is well centered in respect to the central pins (S fig 1) and pushed tight to flange (F fig 2). Tapes of different widths may be centered by removing or adding flanges, available in various thickness.
- 3) that the adhesive tape unroll tension is well regulated, turning knob (9 fig 2)

FILM CUTTING

Fix the film to registration pins (C-U fig 3) and use the straight cut (18 fig 3) for picture and the diagonal one for magnetic (only on M3 35mm 2T model).

FILM SPLICING

Fix the two film ends to be spliced to the registration pins (B-Z and C-U fig 4) ensuring they butt accurately at matrix center using if needed the regulation knob (7 fig 4).

Pull adhesive tape end (G fig 5) forward and fix it on bridge (G fig 5) ensuring that tape is well stretched and adhering to bridge to facilitate the cut, then smooth it down on film, taking care to avoid wrinkles and air-bubbles.

Lower the top casting (AC fig 6) and push the handle (AD fig 6) as far as it will go.

If needed, repeat the operation on reverse side of film.

The operations for the use are identical for all the following 35mm film splicer models:

- M2-35mm
- M3-35mm & Special version
- M3-35mm 2T & Special version
- M3-35mmNEGATIVE Special
- M3-35mm CINEMASCOPE Special
- M3-35mmNeg/2Frames Special
- M3-35mm Pos/2Frames Special

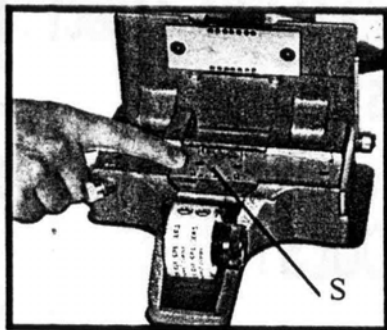

Fig.1

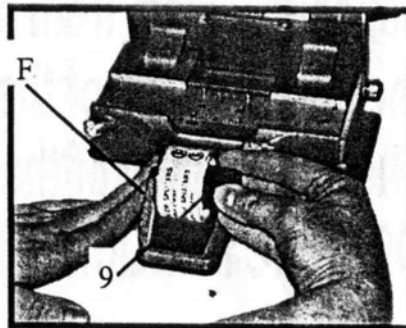

Fig.2

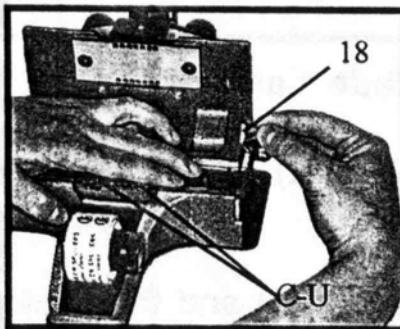

Fig3

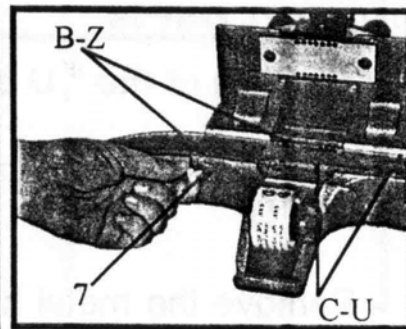

Fig.4

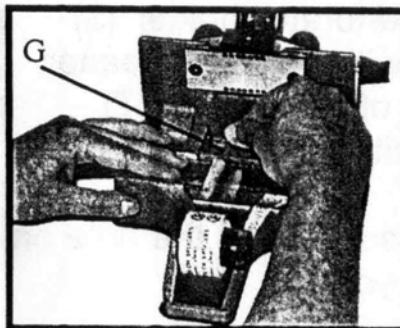

Fig.5

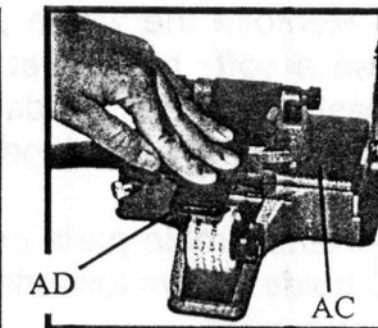

Fig.6

SPLICER SERVICING

This splicer does not require special servicing. All that is needed is to remove the adhesive deposits which, from time to time, collect on the cutting parts of the splicer.

The dismantling of these parts to be cleaned **DOES NOT REQUIRE TOOLS !**

! During maintenance and technical adjustment operations, be VERY carefull with handling of the splicer cutting parts.

Cleaning of the " U blade " and perforator

- Unscrew left milled knob (12) and remove lever axis (11)
- Remove the metal handle (4) and the pressure piece (13).
- Remove the whole perforator holder (3) and use a soft brush wet with suitable cleaner to wash out from inside of U blade (17) and perforator (5) any deposit of glue.
- Reassemble parts ensuring that the hole on the U blade shows towards you

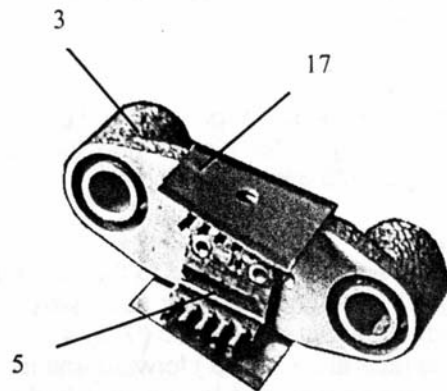
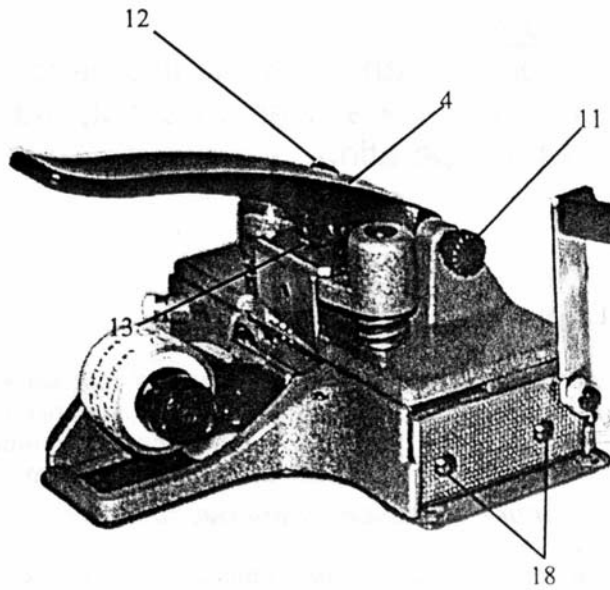

During maintenance and technical adjustment operations, be VERY carefull with handling of the splicer cutting parts.

! During maintenance and technical adjustment operations, be VERY carefull with handling of the splicer cutting parts.

**NEVER SHARPEN THE "U" BLADE AND PERFORATOR HEADS ,
JUST KEEP THEM CLEAN !**

CLEANING OF THE MATRIX :

Remove the adhesive tape layers from matrix centre but do not clean the little rectangles of adhesive tape cut off by the perforator, from the matrix holes.

Clean the matrix edges along which tape is cut by the U blade with a suitable cleaner.

Remember to reapply 3 or 4 layers of adhesive tape on matrix centre.

**TRIMMING LINE REGULATION OF
SIDE CUTTER ASSEMBLY (18) :**

If for any reason, the trimming line gets out of place, re-adjust it with the two screws (18).

This is however a delicate operation which requires technicians' skill and precision.

CIR srl

**Str.Prov. per Tolfa Km. 0,700
00050 Santa Severa RM-Italy
Tel. + 39 0766 570008- 570181
Fax 571390
e-mail cirsrl@tin.it
Web : www.cir-srl.com**