

Film-Tech

The information contained in this Adobe Acrobat pdf file is provided at your own risk and good judgment.

These manuals are designed to facilitate the exchange of information related to cinema projection and film handling, with no warranties nor obligations from the authors, for qualified field service engineers.

If you are not a qualified technician, please make no adjustments to anything you may read about in these Adobe manual downloads.

www.film-tech.com



KELMAR RTV-8200 REWIND SYSTEM
INSTALLATION OPERATING INSTRUCTIONS

General Comments:

The RTV-8200 includes rugged mode and direction selector switches, plus an infinitely variable D.C. motor and heavy duty motor control module. The RTV-8200 allows for precision speed adjustment for inspection, rewinding, and shipping out to small diameter exchange reels. A wide variety of interchangeable shafts makes the RTV-8200 suitable for use in all situations.

RTV-8200 Installation Instructions:

1. Start installation by unpacking the table and all components. Verify all components, etc. against the hardware list.
2. Locate the table top (white side up) and set on blocks so that the cutout is at the lower right. Install the eight 1/4"-20 x 1-3/4" long square neck (carriage) bolts through the top in the eight holes as shown on drawing.
3. Turn the top over so that the cutout is at the lower left (white side down). Be certain to protect the top from scratching.
4. Both leg units are identical. It should be noted that the holes for braces should be located toward the top (away from the cutout).
5. Position a leg assembly over the two 1/4"-20 bolts and the blind hole on the left side of the top so that the smooth side of the angle faces the edge of the top. Fasten this unit to the top using one lag bolt with flat washer and two 1/4"-20 nuts, flat washers and lock washers.
6. In a similar fashion, install the opposite leg unit.
7. Install the two cross braces on the inside of the leg units with the five 1/4"-20 x 5/8" bolts, washers, and lock washers provided.
8. Square up the legs and tighten all fasteners securely.

2--RTV-8200 Rewind System

9. Install the four glides, placing a nut on either side of the flange of the leg unit. These glides should be adjusted and locked when the table is in its final position.
10. Fasten the motor control module to the table top using the four #10 x 3/4" pan head sheet metal screws.
11. Turn the table over, set in position, level the glides, and lock them securely.

It should be noted that it is not necessary to remove the covers of the table top units for installation.

12. Install the drag head to the left side of the table using four 1/4"-20 x 1-3/4" bolts and flat washers.
13. Install the power head to the right side of the table using four 1/4"-20 x 1-3/4" bolts and flat washers.
14. Drop the drive belt through the cutout in the table top, being certain that it is engaged on the pulley of the power head.
15. Pull the wire of the power head through the cutout, and plug it into the rear of the motor control module.
16. Install the motor mounting brackets to the four 1/4"-20 bolts extending through the top. Secure and tighten the bracket with four 1/4"-20 kee nuts. Facing the table, this bracket is positioned so that the four motor mounting slots are to the left.
17. Slip the drive belt over the pulley of the motor and fasten the motor to the bracket with four 10/32" x 3/8" socket head cap screws and flat washers. Plug motor into control module.
18. Adjust belt tension with unit running. Proper tension will be when unit is quietest.
19. Apply the two paste-on tie wrap anchors to the underside of the table and fasten the wires to them, making certain that they are clear from all belts or moving parts.
20. Install the auto shutoff arm and roller. A nylon washer is used for shipment only and should be discarded.
21. After locating table in its final position, it is suggested that it be anchored to the floor with the hole in the bottom of each leg unit, or fastened to wall using an angle bracket.
22. Plug line cord into 115 VAC, 60 Hz outlet. Table is now ready for operation.

3--RTV-8200 Rewind System

Operating Instructions:

1. The RTV-8200 can be used for 1/2" or 5/16" reels. As shipped, the device is optimized for 1/2" or 5/16" operation. If 5/16" capability is ordered, two 5/16" reel support shafts with pin drive (large reels), P/N 7525160-2 (red), and two 5/16" reel support shafts with key drive, P/N 7635160-4 (black), are included.

If 1/2" capability is ordered, two 5/16" reel support shafts with key drive, P/N 7615160-4 (black), and two 1/2" reel support shafts with pin drive, P/N 7525160-1 (blue), are included.

An optional 5/16" shaft with eccentric finger hold drive, P/N 7645160-3, is also available.

2. The motor control module of the RTV-8200 has the following controls:
 - a) Reverse-off-forward selector switch
 - b) Auto-manual mode selector switch
 - c) Stop button
 - d) Motor on light (indicates that speed control is energized)
 - e) Manual start button
 - f) Speed control with dial

In addition to the control module, there are two control switches in the power head that are activated by the auto shutoff arm. These switches provide for auto start, auto shutoff, and manual mode safety interlock.

3. In all cases, the control should be energized with the speed control set at 0, to eliminate snapping the film.
4. For manual operation, during show make-up and breakdown, set auto-manual selector switch to the manual mode, set speed control to 0, select direction desired, and press the manual start button. The indicator light will come on, indicating that there is power to the speed control, and that by turning up the control, the motor will start to turn. Use the speed control to start and stop. If it is necessary to back up to a splice, etc., turn the speed control back to 0, change the direction selector switch to reverse and press the manual start button again. During manual operation, the auto shutoff arm must be against its lower stop, or the control will not be energized.
5. If it is necessary to stop, during any mode, press the stop button. After the device is stopped by the stop button, return speed control to 0 and restart.
6. For automatic operation, set auto-manual selector to auto position, and raise auto shutoff arm until it rests on its internal stop. Thread the film onto the reel and remove any tension by rotating the reels by hand.

4--RTV-8200 Rewind System

Check that the speed control is at 0 and raise the arm until the indicator light comes on, lower the arm onto the film and advance the speed control to the desired speed. As the film runs through, the arm will drop, shutting off the device.

7. Correct speed for large reels should not exceed 80 on the dial. Higher speeds will result in damage to film, reels, etc. Full speed should be used for small shipping reels only.
8. When the device is not in use, set the reverse-off-forward selector switch to the "off" position.



Kelmar Systems Inc.

RTV-8200 HARDWARE LIST

Table:

4	Glides
8	3/8"-16 Hex Nuts
5	1/4"-20 x 5/8" Hex Head Cap Screws
9	1/4"-20 Hex Nuts
9	1/4" Split Lock Washers
11	1/4" Flat Washers
2	1/4" Lag Bolts
4	1/4"-20 x 1-3/4" Square Neck (Carriage) Bolts

Rewinder:

4	1/4"-20 x 1-3/4" Square Neck (Carriage) Bolts
8	1/4"-20 x 1-3/4" Hex Head Cap Screws
12	1/4" Flat Washers
4	1/4"-20 Kep Nuts
4	#10 x 3/4" Pan Head Sheet Metal Screws
4	10/32" x 3/8" Socket Head Cap Screws
4	#10 Flat Washers
2	Tie Wrap Anchors
2	Tie Wraps
1	5/32" Hex Wrench
1	1/8" Hex Wrench
1	7/64" Hex Wrench
1	3/32" Hex Wrench
2	7525160-1 Reel Support Shaft Assemblies for 1/2" System
2	7635160-4
	or
2	7525160-2 Reel Support Shaft Assemblies for 5/16" System
2	7635160-4

Custom Sound, Control and Projection Systems

284 Broadway Huntington Station New York 11746 516-692-6131

RTV-8200 POWER REWIND PARTS LIST

<u>PART NO.</u>	<u>DESCRIPTION</u>
7525151	Power Side Assembly
7525152	Dead Side Assembly
7625055	Cable, Motor Control to Power Head
7415155	Legs, Table
7415156	Brace, Table
7415157	Top, Table
7525158	Cover, Power Side
7525159	Cover, Dead Side
7525160-1	Shaft, Reel Support, Assembly - 1/2" (Blue)
7525160-2	Shaft, Reel Support, Assembly - 5/16" w/Drive Pin (Red)
7645160-3	Shaft, Reel Support, Assembly - 5/16" w/Finger Hole Drive
✓ 7635160-4	Shaft, Reel Support, Assembly - 5/16" w/Drive Key (Black) ✓
7525160-5	Shaft, Reel Support, Assembly - 70mm w/Drive Pin
7525160-6	Shaft, Reel Support, Assembly - 16mm
7525161	Frame, Power Side
7525162	Frame, Dead Side
7415163	Pulley, Main Shaft, Power Side
7415164	Plate, Clutch, Dead Side
7415165	Pulley, Motor, Power Side
7415166	Spacer, Clutch Plate to Frame, Dead Side
7525167	Shaft, Main, Power Side
7525168	Shaft, Main, Dead Side
7525169	Collar, Ball Detent
7415170	Extension, Shaft, Dead Side
7415174	Plate, Pressure, Clutch, Dead Side
7415175	Pulley, Jack Shaft to Main Shaft, Power Side
7415176	Pulley, Jack Shaft to Motor, Power Side
7415177	Shaft, Jack
7635178	Motor Mounting Bracket
7415179-1	Bearing, Main Shaft
7415179-2	Flange, Bearing, Main Shaft
7525180-1	Bearing, Jack Shaft
7525180-2	Flange, Bearing, Jack Shaft
7415181	Key, Square, Main Shaft

2--RTV-8200 Power Rewind Parts List

<u>PART NO.</u>	<u>DESCRIPTION</u>
7415182-1	Key, Square, Jack Shaft, Long
7415182-2	Key, Square, Jack Shaft, Short
7525183	Detent, Ball
7525184	Bushing, Shaft Storing
7415185	Knob, Auto Shutoff
7635186	Pin, Drive, Reel Support Assembly
7525189	Flange, Mounting, Auto Shutoff
7525190	Shaft, Auto Shutoff
7415191	Arm, Roller, Auto Shutoff
7415192	Cam, Intermediate Rest and Stop, Auto Shutoff
7525193	Shaft, Roller, Auto Shutoff, 35mm
7525194	Stud, Stop, Auto Shutoff
7415195	Cam, Start, Auto Shutoff
7402078	Roller, Auto Shutoff, 35mm
7402079	Roller, Auto Shutoff, 70mm
7525197	Shaft, 70mm Roller, Auto Shutoff
7415202	Motor, D.C., Motronics
7525203	Spacer, Motor Mount
7525204	Bushing, Isolation, Motor Mount
7525205	Standoff, Bearing, Jack Shaft
7415206	Rest (Modified), Intermediate, Auto Shutoff
7415207	Bracket, Intermediate Rest, Auto Shutoff
7415208	Bumper, Rubber
7415210	Spacer, Switch Mounting, Auto Shutoff
7415213	Belt, Jack Shaft to Main Shaft
7525214	Belt, Motor to Jack Shaft
7643177	Micro Switch
8225154	Module, Speed Control, Complete

OTHER OPTIONS:

7305277	Film Measuring Machine Bracket
7525220	Trailer Flange
7713030	Handle

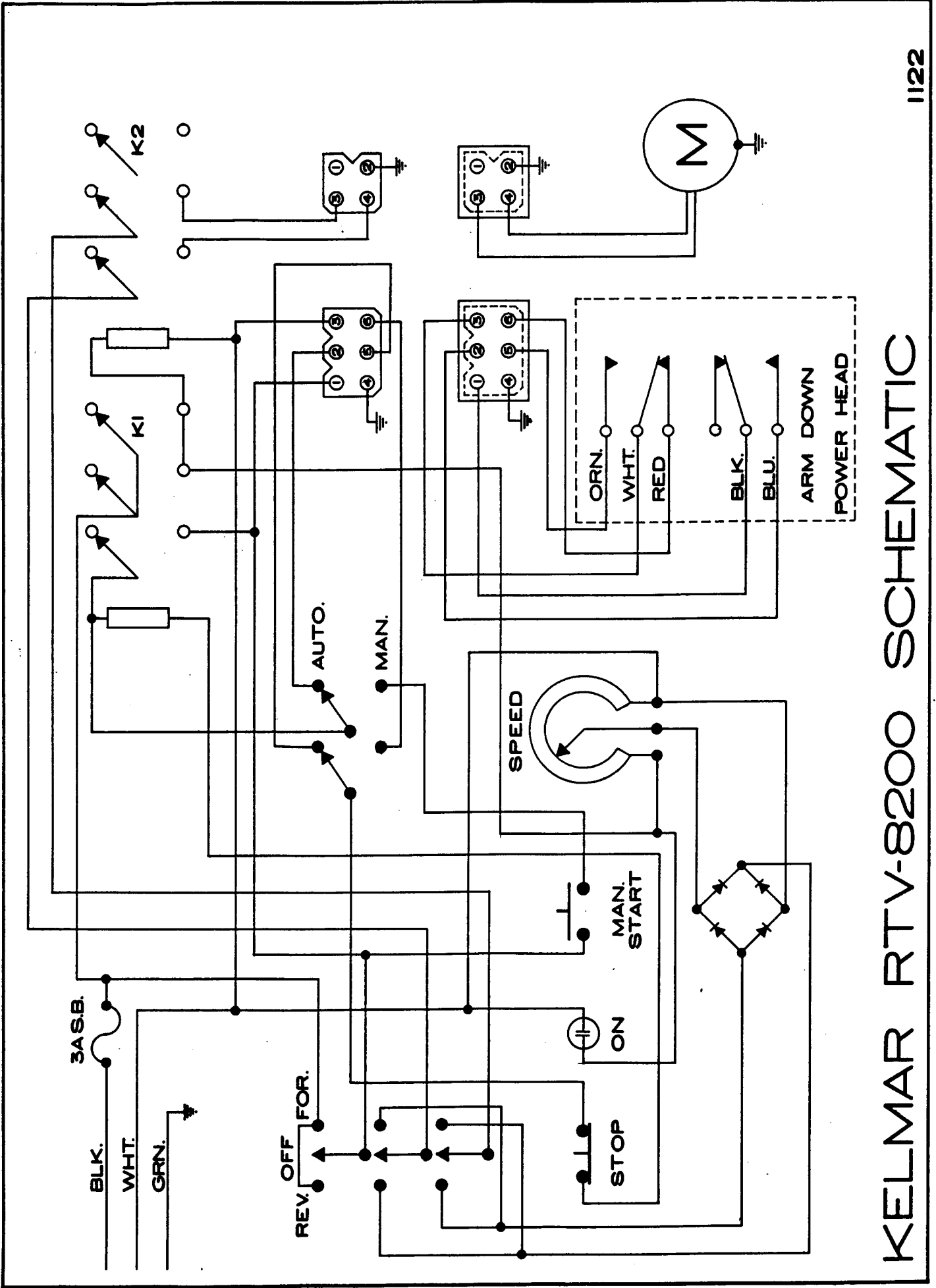

KELMAR RTV-8200 SCHEMATIC

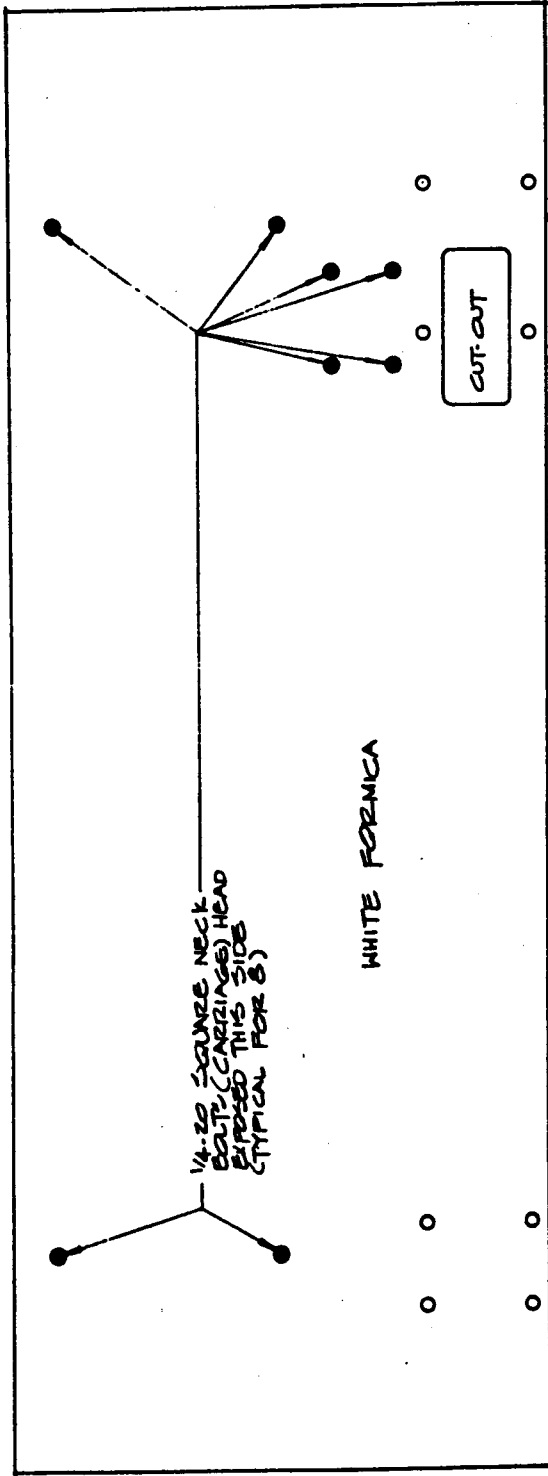

REVISED

RTV-7509/B200
FORMICA TABLE

 Kalmat Systems Inc.

201 Broadway, Manhattan, New York 10014 (212) 693-1111

Date: JAN 76	Scale: 5" = 1'-0"	Drawn by: ONE
Job No:	File No:	Dwg No: 738