

# Film-Tech

The information contained in this Adobe Acrobat pdf file is provided at your own risk and good judgment.

These manuals are designed to facilitate the exchange of information related to cinema projection and film handling, with no warranties nor obligations from the authors, for qualified field service engineers.

If you are not a qualified technician, please make no adjustments to anything you may read about in these Adobe manual downloads

[www.film-tech.com](http://www.film-tech.com)

STRONG MODEL "SD"  
AUDITORIUM DIMMER  
INSTRUCTION MANUAL

STRONG INTERNATIONAL/BALLANTYNE OF OMAHA  
1712 JACKSON STREET  
OMAHA, NE 68102

402-342-4444

Raven Laboratories  
87 Central Ave.  
Glen Rock, N.J. 07452  
Phone: (201) 444-7766  
Fax: (201) 444-7793

**TABLE OF CONTENTS**

<u>DESCRIPTION</u>	<u>PARA#</u>	<u>PAGE#</u>
SCOPE .....	1.0	3
GENERAL .....	2.0	3
UNPACKING .....	3.0	4
SYSTEM DESCRIPTION .....	4.0	4
MOUNTING CHASSIS .....	5.0	4
ELECTRICAL INSTALLATION .....	6.0	5
CONTROL BOARD ADJUSTMENTS .....	7.0	6
PANEL CONTROLS .....	8.0	7
TECHNICAL SPECIFICATIONS .....	9.0	8
IMPORTANT INFORMATION .....	10.0	8
PARTS LIST .....	11.0	9

**DRAWINGS**

<u>DESCRIPTION</u>	<u>FIG#</u>	<u>PAGE#</u>
CONTROL BOARD ADJUSTMENTS .....	1.0	11
CONTROL BOARD COMPONENTS .....	2.0	12
POWER MODULE COMPONENTS .....	3.0	13
POWER MODULE SCHEMATIC .....	4.0	14
SYSTEM INTERCONNECT SCHEMATIC (WALL) ...	5.0	15
SYSTEM INTERCONNECT SCHEMATIC (SPA-5) ..	6.0	16

**APPENDIX**

<u>DESCRIPTION</u>	<u>APPEND#</u>	<u>PAGE#</u>
DISCREET OPERATION .....	1.0	17
WIRING ADDITIONAL POWER MODULES .....	2.0	18

## 1.0 SCOPE

THIS MANUAL IS INTENDED TO PROVIDE INSTALLATION AND OPERATIONAL INSTRUCTIONS FOR THE STRONG MODEL "SD" SERIES AUDITORIUM DIMMER SYSTEM.

## 2.0 GENERAL

THE STRONG MODEL "SD" SERIES DIMMER COMES IN ONE OF TWO CONFIGURATIONS BASED ON THE TYPE OF AUTOMATION USED TO CONTROL THE LIGHT FUNCTIONS. FURTHER MORE THE DIMMER IS DESIGNED TO CONTROL ONE OR TWO SEPERATE LIGHT CIRCUITS EITHER DISCREETLY OR IN CONJUNCTION WITH EACH OTHER.

### 2.1 WALL MOUNT VERSION

THIS VERSION HAS THE CONTROL BOARD AND POWER MODULES BUILT INTO ONE CHASSIS THAT IS MOUNTED ON THE WALL. BASED ON YOUR REQUIREMENTS THIS UNIT CAN CONTROL BOTH HOUSE AND STAGE LIGHTS AND CAN BE EXPANDED TO CONTROL UP TO 8000 WATTS OF LIGHTING IN THE SAME CHASSIS. FURTHER EXPANSION WOULD ONLY REQUIRE MOUNTING AN ADDITIONAL POWER MODULE CHASSIS.

### 2.2 SPA-5(A) VERSION

THIS VERSION IS VERY SIMILAR TO THE WALL MOUNT VERSION WITH THE EXCEPTION THAT THE CONTROL BOARD IS MOUNTED IN THE AUTOMATION SYSTEM AND THE INTENSITY CONTROLS ARE LOCATED ON THE AUTOMATION CONTROL PANEL. THE POWER MODULES ARE MOUNTED IN A SEPERATE CHASSIS WHICH IS MOUNTED ON THE WALL AND LOW VOLTAGE CONTROL WIRING MUST BE PROVIDED FROM THE AUTOMATION TO THE POWER MODULE CHASSIS.

N O T E: THE AUTOMATION MUST BE ON THE SAME ELECTRICAL PHASE AS THE AUTOMATION SYSTEM IN THIS TYPE CONFIGURATION.

### 2.3 MODEL SD-1

THIS UNIT COMES IN EITHER THE WALL MOUNT OR SPA-5(A) VERSION AND IS DESIGNED TO CONTROL HOUSE LIGHTS ONLY. THE STANDARD UNIT IS CAPABLE OF CONTROLLING 2000 WATTS OF LIGHTING AND IS EXPANDABLE BY ADDING ADDITIONAL POWER MODULES IN INCRIMENTS OF 2000 WATTS.

### 2.4 MODEL SD-2

THIS UNIT COMES IN EITHER THE WALL MOUNT OR SPA-5(A) VERSION AND IS DESIGNED TO CONTROL BOTH HOUSE AND STAGE LIGHTS IN CONJUNCTION WITH EACH OTHER. BOTH HOUSE AND STAGE LIGHT CIRCUITS CAN BE 2000 WATTS EACH AND ARE EXPANDABLE BY ADDING ADDITONAL POWER MODULES. WITH A MINOR CIRCUIT MODIFICATION THE SD-2 CAN CONTROL BOTH HOUSE AND STAGE LIGHTS DISCREETLY - SEE APPENDIX 1.0.

### 2.5 HALF LIGHT LEVELS

BOTH THE SD-1 AND SD-2 CAN BE CONFIGURED TO PROVIDE HALF LIGHT LEVELS BASED ON THE AUTOMATION SYSTEMS ABILITY TO PROVIDE SUCH SIGNALS.

### 3.0 UNPACKING INSTRUCTIONS

UPON RECEIPT OF YOUR AUDITORIUM DIMMER SYSTEMS YOU SHOULD UNPACK THEM IMMEDIATELY AND INSPECT FOR ANY FREIGHT DAMAGE AND VERIFY THAT THE NUMBER RECEIVED CORRESPONDS TO THE NUMBER SHIPPED ON THE PACKING LIST.

### 4.0 SYSTEM DESCRIPTION

THE STRONG SERIES "SD" DIMMER IS A FULL FUNCTION INCANDESCENT LIGHTING CONTROL SYSTEM DEVELOPED FOR MOTION PICTURE THEATRE USE. ITS' FEATURES INCLUDE:

SOFT START TO EXTEND LIGHT BULB LIFE.

PRESET BRIGHT LEVELS TO MINIMIZE ELECTRICAL COSTS.

ADJUSTABLE SPEED CONTROLS TO ENHANCE PRESENTATIONS.

HALF LEVEL CAPABILITY TO PROVIDE CROWD CONTROL.

THE BASIC SYSTEM IS RATED AT 2KW AND IS EXPANDABLE IN INCRIMENTS OF 2000 WATTS. THE "SD" DIMMER IS DESIGNED TO OPERATE WITH ANY AUTOMATION SYSTEM IS CAPABLE OF PROVIDING PULSED DRY CONTACT LOGIC.

THE STRONG SERIES "SD" DIMMER UTILIZES A NEW AND DIFFERENT TYPE OF LIGHT MODULATION THAT ALLOWS PRECISE AND PREDICTABLE CONTROL OVER THE LIGHTING LOAD, AND IS NOT SUBJECT TO LOW FIRING ANGLE PHASE JITTER, OR FALSE TURN-ON BY XENON BULB IGNITION OR CHANGE-OVER ACTIVATION. FURTHERMORE, THE CIRCUIT IS DESIGNED TO ELIMINATE UNWANTED SOUND SYSTEM INTERFERENCE.

### 5.0 MOUNTING THE CHASSIS UNIT

#### 5.1

REMOVE THE FOUR OR SIX SCREWS THAT SECURE THE FRONT COVER TO THE CHASSIS. PLACE THE SCREWS BACK IN THE UNIT AFTER REMOVING THE FRONT COVER SO THAT THEY DON'T GET MISPLACED.

#### 5.2

LOCATE THE AREA ON THE WALL THAT THE CHASSIS UNIT WILL BE MOUNTED. IT IS ADVISABLE TO LOCATE THE CHASSIS IN CLOSE PROXIMITY TO THE BOOTH POWER PANEL TO MINIMIZE HIGH VOLTAGE WIRING.

#### 5.3

USE A TORPEDO LEVEL ON TOP OF THE CHASSIS TO ASCERTAIN THAT IT IS LEVEL AND MARK THE FOUR MOUNTING HOLES TO BE DRILLED.

#### 5.4

DRILL THE FOUR MOUNTING HOLES TO ACCOMMODATE 1/4-20 LAG BOLT INSTALLATION.

#### 5.5

USE A CHASSIS PUNCH TO PLACE ANY ADDITIONAL HOLES IN THE CHASSIS THAT MAY BE REQUIRED FOR ELECTRICAL WIRING.

#### 5.6

MOUNT THE CHASSIS UNIT ON THE WALL USING 1/4-20 LAG BOLTS.

## 6.0 ELECTRICAL INSTALLATION

N O T E: BE CERTAIN THAT ALL ELECTRICAL POWER IS OFF.

### 6.1 GENERAL INFORMATION

#### 6.1.1

EACH POWER MODULE SHOULD BE PROTECTED BY A 20 AMP, 115 VOLT AC CIRCUIT BREAKER WHICH SHOULD BE INSTALLED IN THE BOOTH CIRCUIT BREAKER PANEL IN CLOSE PROXIMITY TO THE POWER MODULE CHASSIS UNIT. ALL POWER MODULES FOR AN INDIVIDUAL AUDITORIUM MUST BE ON THE SAME ELECTRICAL PHASE. ON THE SPA-5(A) VERSION THE AUTOMATION MUST ALSO BE ON THE SAME ELECTRICAL PHASE AS THE POWER MODULES. TO PREVENT DAMAGE TO THE POWER MODULES ALWAYS CHECK THE LOAD CIRCUIT WITH AN OHMMETER PRIOR TO CONNECTING TO THE POWER MODULES. A SHORT IN THE LOAD CIRCUIT WILL DESTROY THE POWER MODULES TRIAC.

### 6.2 WALL MOUNT VERSION

#### 6.2.1

RUN ONE 12 AWG WIRE FROM EACH POWER MODULE TERMINAL LABELED [LINE] TO THE BOOTH CIRCUIT BREAKER PANEL. CONNECT EACH WIRE TO A 20 AMP 115 VOLT AC CIRCUIT BREAKER AND MARK CIRCUIT BREAKER ACCORDINGLY.

#### 6.2.2

RUN ONE 12 AWG WIRE FROM THE DIMMER CONTROL BOARD TERMINAL LABELED [AC LO #2] TO THE BOOTH CIRCUIT BREAKER PANEL AND CONNECT TO THE NEUTRAL BUSS.

#### 6.2.3

CONNECT THE INDIVIDUAL AUDITORIUM LIGHTING CIRCUITS TO THE RESPECTIVE POWER MODULE LABELED [LOAD]. NOTE: A MAXIMUM LOAD OF 2000 WATTS PER POWER MODULE MUST BE OBSERVED. FOR GREATER LOADS ADD ADDITIONAL POWER MODULES - REFER TO APPENDIX 1.0.

#### 6.2.4

CONNECTION OF THE CONTROL WIRES FROM THE AUTOMATION SYSTEM IS ACCOMPLISHED AT THE TERMINAL STRIP LOCATED ON THE DIMMER CONTROL BOARD. THESE MUST BE DRY CONTACTS AS THE DIMMER CONTROL BOARD PROVIDES ITS' OWN VOLTAGE SOURCE. IF YOU ONLY HAVE AN SD-1 DIMMER AND DO NOT REQUIRE HALF LIGHT LEVELS THEN DISREGARD THE CONNECTIONS FOR THE STAGE LIGHT CIRCUIT. THE AUTOMATION SYSTEM SHOULD PROVIDE MOMENTARY CONTACTS FOR CONTROL OF THE INDIVIDUAL CIRCUITS.

<u>FUNCTION</u>	<u>CONNECTION</u>
SWITCH LEG	TERM #10 [COM]
HOUSE BRIGHT-HALF LEVEL 2	TERM #11 [HSE B]
HOUSE DIM-FULL DIM	TERM #12 [HSE D]
STAGE BRIGHT-FULL BRIGHT	TERM #13 [STG B]
STAGE DIM-HALF LEVEL 1	TERM #14 [STG D]

6.3 SPA-5(A) VERSION

6.3.1

RUN ONE 12 AWG WIRE FROM EACH POWER MODULE TERMINAL LABELED [LINE] TO THE BOOTH CIRCUIT BREAKER PANEL. CONNECT EACH WIRE TO A 20 AMP 115 VOLT AC CIRCUIT BREAKER AND MARK CIRCUIT BREAKER ACCORDINGLY.

6.3.2

CONNECT THE INDIVIDUAL AUDITORIUM LIGHTING CIRCUITS TO THE RESPECTIVE POWER MODULES LABELED [LOAD]. NOTE: A MAXIMUM LOAD OF 2000 WATTS PER POWER MODULE MUST BE OBSERVED. FOR GREATER LOADS ADD ADDITIONAL POWER MODULES - REFER TO APPENDIX 2.0.

N O T E: THE POWER MODULES MUST BE ON THE SAME ELECTRICAL PHASE AS THE AUTOMATION SYSTEM.

6.3.3

RUN 4 EACH 16 AWG OR SMALLER WIRES FROM THE AUTOMATION TERMINAL STRIP TO THE POWER MODULE CHASSIS AND CONNECT AS FOLLOWS:

<u>AUTO TERM #</u>	<u>CONNECTION</u>
4	HOUSE POWER MOD [-]
5	HOUSE POWER MOD [+]
6	STAGE POWER MOD [-]
7	STAGE POWER MOD [+]

7.0 DIMMER CONTROL BOARD ADJUSTMENTS

(REFER TO FIGURE 1.0)

7.1 WHEN NOT USING HALF LEVEL OR WHEN USING DISCRKET CIRCUIT.

<u>ADJUSTMENT</u>	<u>CONTROLS</u>
P-1	THE RATE OF SPEED THAT THE HOUSE LIGHTS GO FROM DIM TO BRIGHT AND BRIGHT TO DIM.
P-2	THE RATE OF SPEED THAT THE STAGE LIGHTS GO FROM DIM TO BRIGHT AND BRIGHT TO DIM.
P-3	FACTORY ADJUSTED BALANCE POT.
P-4	SETS THE STAGE LIGHT BRIGHT LEVEL.
P-5	SETS THE STAGE LIGHT DIM LEVEL.

7.2 WHEN USING HALF LEVEL

<u>ADJUSTMENT</u>	<u>CONTROLS</u>
P-1	THE RATE OF SPEED THAT THE HOUSE LIGHTS GO FROM BRIGHT TO DIM AND DIM TO BRIGHT.
P-2	THE RATE OF SPEED THAT THE STAGE LIGHTS GO FROM BRIGHT TO DIM AND DIM TO BRIGHT.
P-3	FACTORY ADJUSTED BALANCE POT.
P-4	SETS BOTH THE HOUSE AND STAGE LIGHTS BRIGHT LEVEL.
P-5	SETS THE STAGE DIM LEVEL.

8.0 FRONT PANEL CONTROLS

8.1 WHEN NOT USING HALF LEVEL  
OR WHEN USING DISCREET CIRCUIT.

<u>ITEM</u>	<u>CONTROLS</u>
STAGE LIGHT DIM	MANUALLY LOWERS STAGE LIGHT LEVEL.
STAGE LIGHT BRT	MANUALLY RAISES STAGE LIGHT LEVEL.
HOUSE LIGHT DIM	MANUALLY LOWERS HOUSE LIGHT LEVEL.
HOUSE LIGHT BRT	MANUALLY RAISES HOUSE LIGHT LEVEL.
BRIGHT LEVEL	SETS THE HOUSE LIGHT BRIGHT LEVEL.
DIM LEVEL	SETS THE HOUSE DIM LEVEL.

NOTE: THE STAGE BRIGHT AND DIM LEVEL IS SET ON THE DIMMER CONTROL BOARD WITH P-4 AND P-5.

8.2 WHEN USING HALF LEVEL

<u>ITEM</u>	<u>CONTROLS</u>
STAGE LIGHT DIM	LOWERS THE STAGE LIGHT TO FULL DIM AND LOWERS HOUSE LIGHTS TO HALF LEVEL.
STAGE LIGHT BRT	RAISES THE STAGE LIGHTS TO FULL BRIGHT AND RAISES HOUSE LIGHTS TO FULL BRIGHT.
HOUSE LIGHT DIM	LOWERS HOUSE LIGHTS FROM HALF LEVEL TO FULL DIM LEVEL.



8.2 CONTINUED

<u>ITEM</u>	<u>CONTROLS</u>
HOUSE LIGHT BRT	RAISES HOUSE LIGHTS FROM FULL DIM LEVEL TO HALF LEVEL.
HALF LEVEL	SETS THE HOUSE LIGHT HALF LEVEL.
DIM LEVEL	SETS THE HOUSE FULL DIM LEVEL.

NOTE: THE STAGE BRIGHT AND DIM LEVEL IS SET ON THE DIMMER CONTROL BOARD WITH P-4 & P-5.

9.0 TECHNICAL SPECIFICATIONS

- 9.1 MAXIMUM LOAD ..... 2000 WATTS PER MODULE.
- 9.2 MAXIMUM LOAD CURRENT ..... 20 AMPS RMS.
- 9.3 PEAK 1 CYCLE LOAD I ..... 250A/60Hz.  
230A/50Hz.
- 9.4 CONTROL CURRENT ..... 5mA MINIMUM.  
11mA TYPICAL.  
50mA MAXIMUM.
- 9.5 CONTROL TO LINE ISOLATION ... 7500 VAC.
- 9.6 CONTROL WIRING ..... CLASS TWO.

10.0 IMPORTANT INFORMATION  
AS PREVIOUSLY DISCUSSED IN THIS MANUAL THE FOLLOWING ITEMS MUST NOT BE OVER LOOKED FOR CORRECT DIMMER OPERATION:

10.1 SAME ELECTRICAL PHASE  
ALL DIMMER POWER MODULES FOR AN INDIVIDUAL AUDITORIUM MUST BE ON THE SAME ELECTRICAL PHASE. WHEN USING THE SPA-5(A) VERSION THE AUTOMATION SYSTEM MUST ALSO BE ON THE SAME PHASE.

10.2 CHECK - FOR - SHORTS - FIRST  
ALWAYS CHECK THE AUDITORIUM LIGHTING CIRCUITS FOR SHORT CIRCUITS PRIOR TO CONNECTING TO THE [LOAD] TERMINAL ON THE INDIVIDUAL POWER MODULES. A SHORT WILL DESTROY THE TRIAC MOUNTED ON THE POWER MODULE.

10.3 LIMIT THE LIGHT LOAD  
EACH POWER MODULE IS CONSERVATIVELY DESIGNED TO CONTROL 2000 WATTS OF LIGHTING. CALCULATE YOUR LOAD AND IF YOU HAVE MORE THAN THAT, ADD ADDITIONAL POWER MODULES.

## 11.0 PARTS LIST

### 11.1 DIMMER CONTROL BOARD (REFER TO FIGURE 2.0)

<u>REFERENCE</u>	<u>DESCRIPTION</u>
R1,R2,R4,R5, R7,R8,R9,R10, R13,R18,R19, R21,R23,R24, R25,R27,R30	4.7K ohm, 1/2 WATT, 5% RESISTOR.
R26,R28,R29	1.0K ohm, 1/2 WATT, 5% RESISTOR.
R14,R17	110 ohm, 1/2 WATT, 5% RESISTOR.
R20	20.0K ohm, 1/2 WATT, 5% RESISTOR.
R11,R12,R15, R16	10.0K ohm, 1/2 WATT, 5% RESISTOR.
R32	10 ohm, 1/2 WATT, 5% RESISTOR.
R3	4.7M ohm, 1/2 WATT, 5% RESISTOR.
R6	1.0M ohm, 1/2 WATT, 5% RESISTOR.
R31	220 ohm, 2 WATT, 5% RESISTOR.
P1,P2	1.0M ohm, 1/4 WATT, CERMET POTENTIOMETER.
P3,P4	50.0K ohm, 1/4 WATT, CERMET POTENTIOMETER.
P5	25.0K ohm, 1/4 WATT, CERMET POTENTIOMETER.
C7,C9	10uf, 50 VDC, CAPACITOR. Polyester
C3,C6,C8,C10, C12,C14	.1uf, 250 VOLT, CAPACITOR.
C16	.047uf, 400 VOLT, CAPACITOR.
C1,C2,C4,C5 C10,C13	.01uf, 100 VDC, CAPACITOR.
C15	100uf, 16 VOLT, CAPACITOR.
D1 thru D4, D6 thru D11	1N4004, 1AMP, 400 VOLT, DIODE.
D5	1N4743, 1 WATT, 13 VOLT, ZENER DIODE.

11.1 CONTINUED

<u>REFERENCE</u>	<u>DESCRIPTION</u>
Q1,Q2	2N3568, NPN, TRANSISTOR.
U1,U2	IC4023 INTEGRATED CIRCUIT.
U3	UA1458 INTEGRATED CIRCUIT.
U4	NE556 INTEGRATED CIRCUIT.
T1	FC-24-180, TRANSFORMER.

11.2 POWER MODULE (REFER TO FIGURE 3.0)

<u>REFERENCE</u>	<u>DESCRIPTION</u>
R1	180 ohm, 1 WATT, 5% RESISTOR.
C1	100 nf, 600 VOLT, CAPACITOR.
D1	1N4004, 1 AMP, 400 VOLT, DIODE.
IC1	MOC-3011, INTEGRATED CIRCUIT.
Q1	SC-160D, TRIAC.
L1	120 uH, 20 AMP, CHOKE.
X1	HEAT SINK.

CONTROL BOARD ADJUSTMENTS

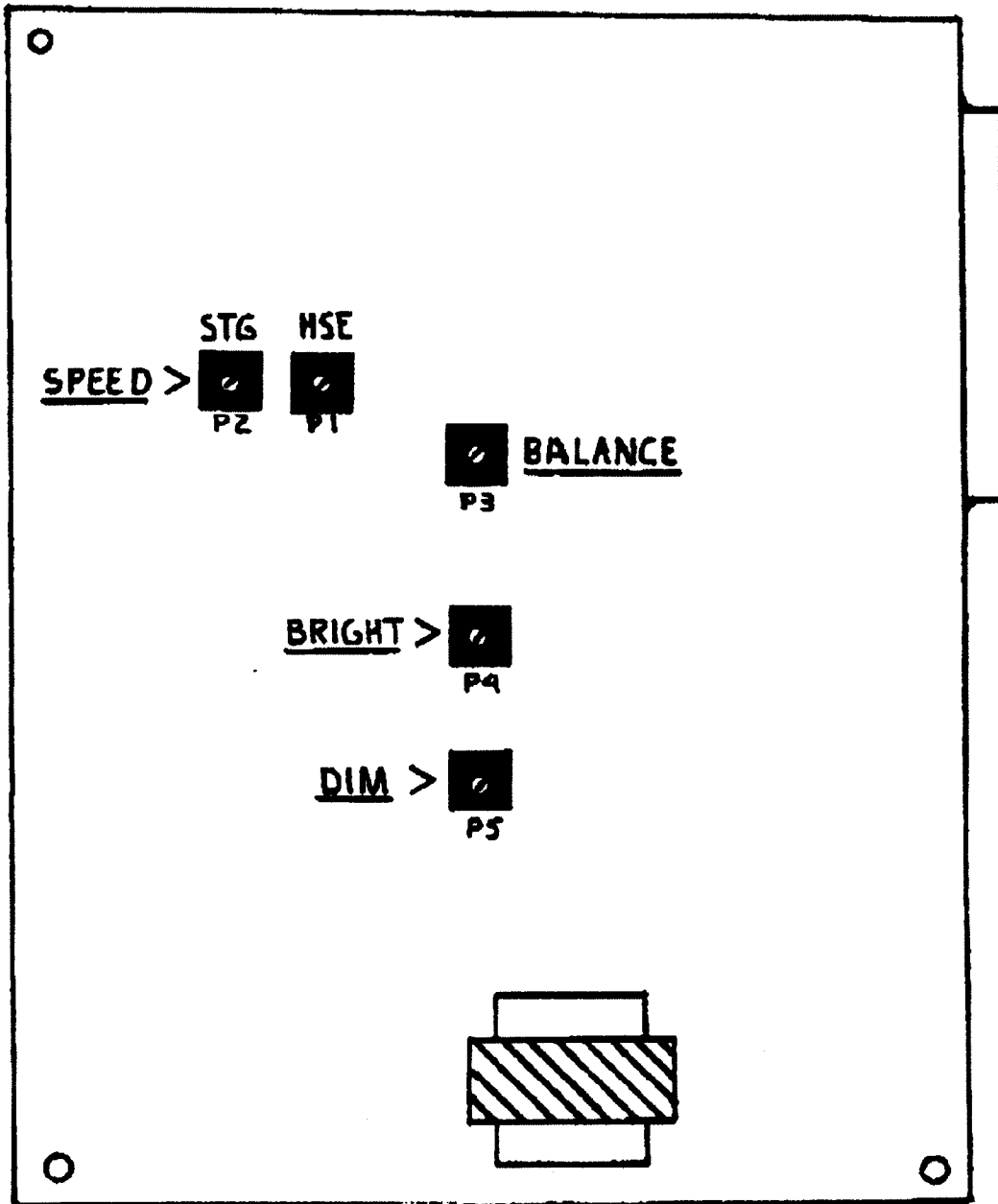

FIGURE 1.0

CONTROL BOARD COMPONENTS

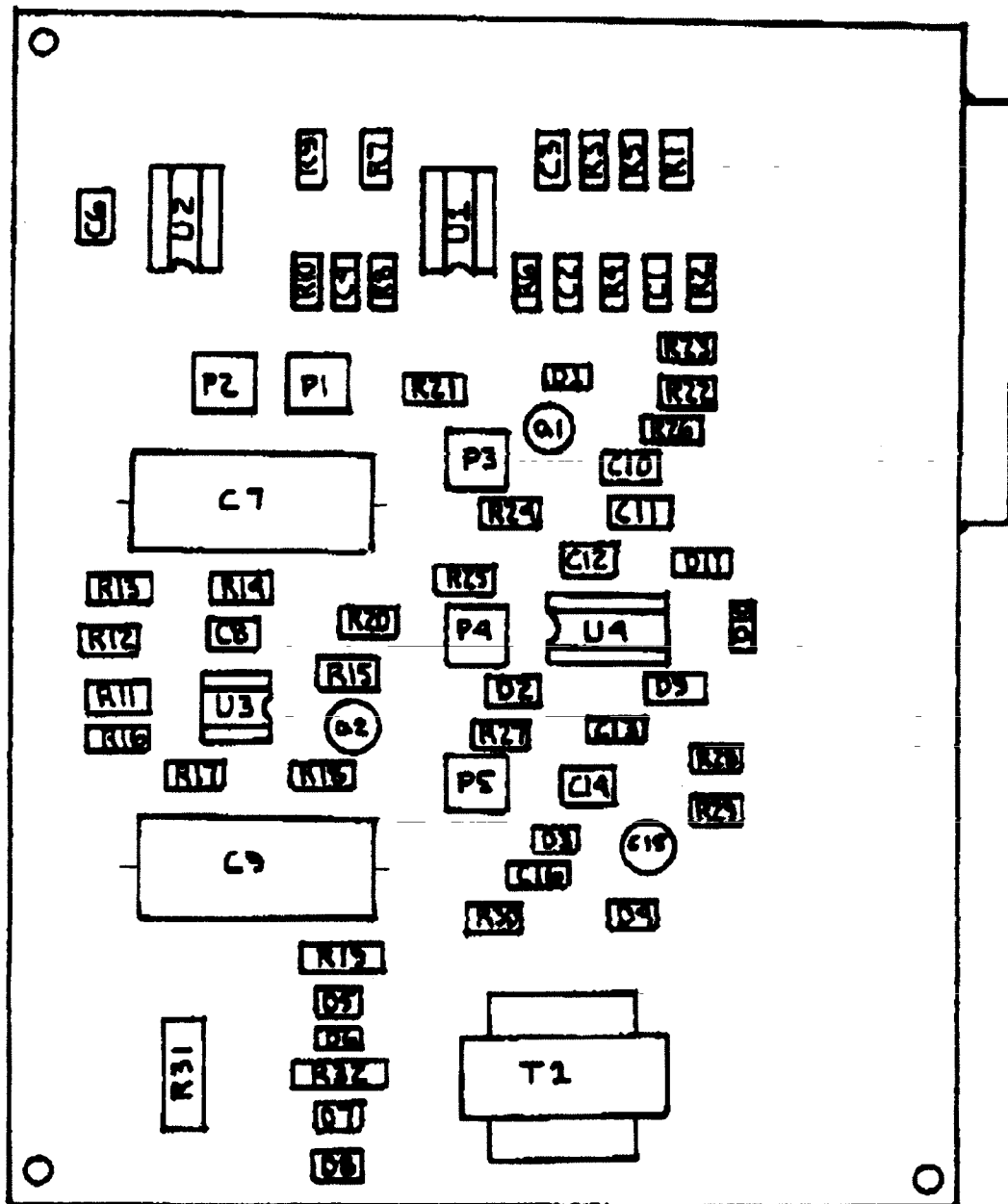
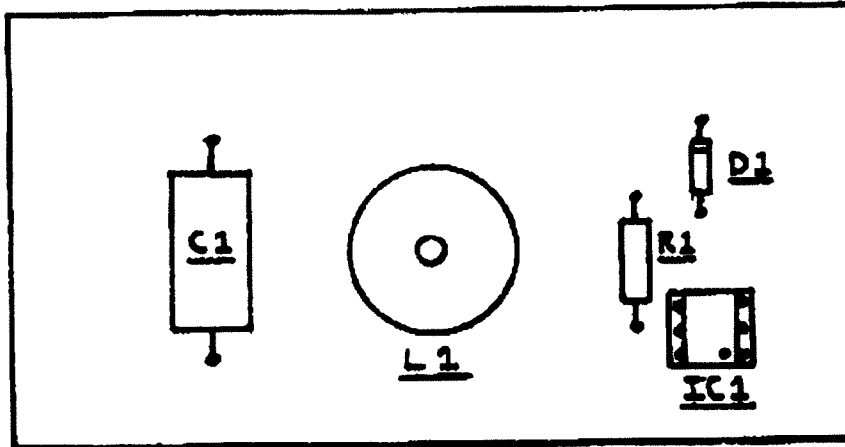

FIGURE 2.0

POWER MODULE COMPONENTS

CIRCUIT BOARD



HEAT SINK

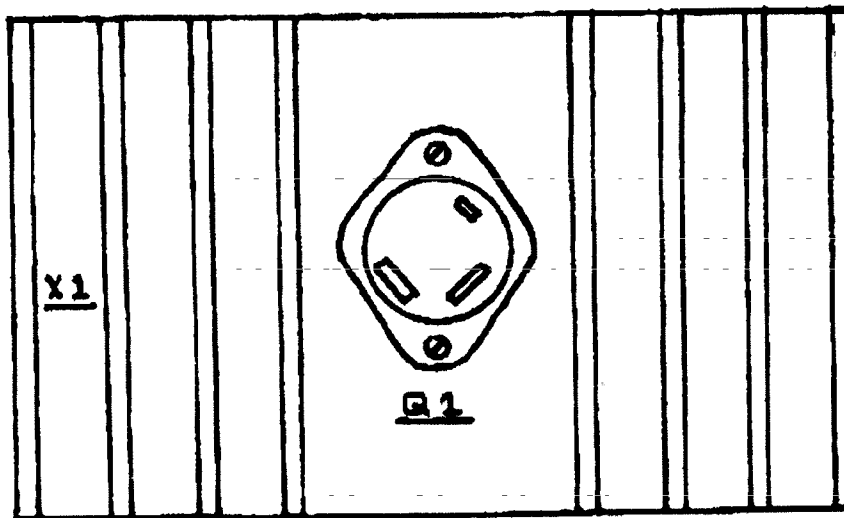

FIGURE 3.0

POWER MODULE SCHEMATIC

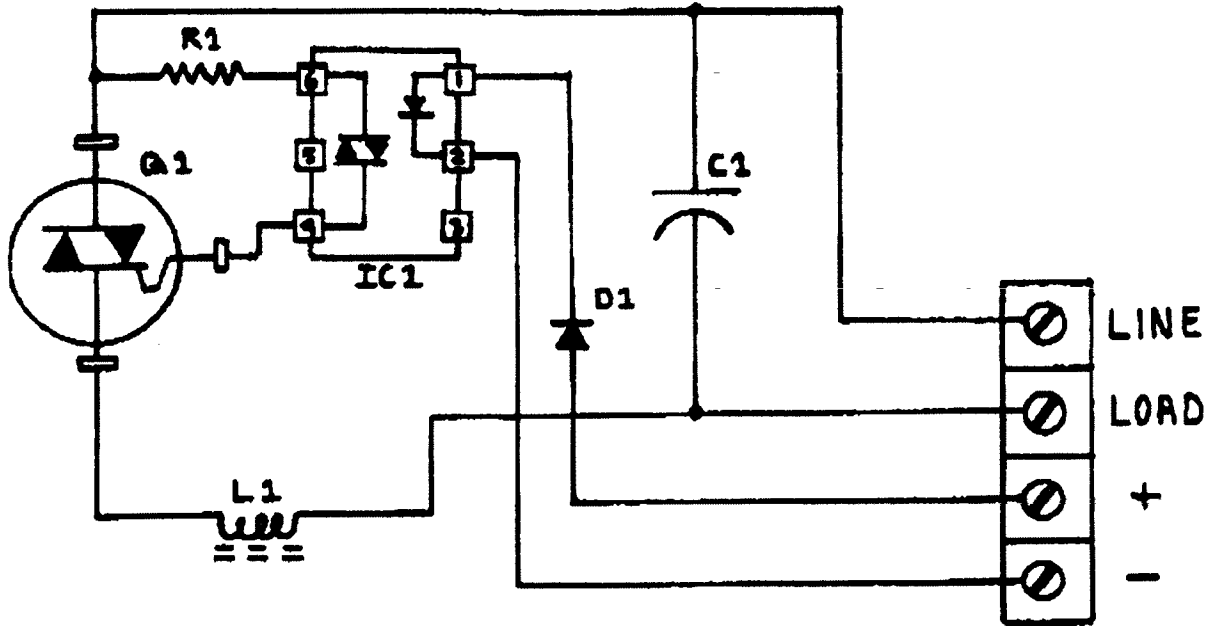

FIGURE 4.0

SYSTEM INTERCONNECT SCHEMATIC  
WALL MOUNT VERSION

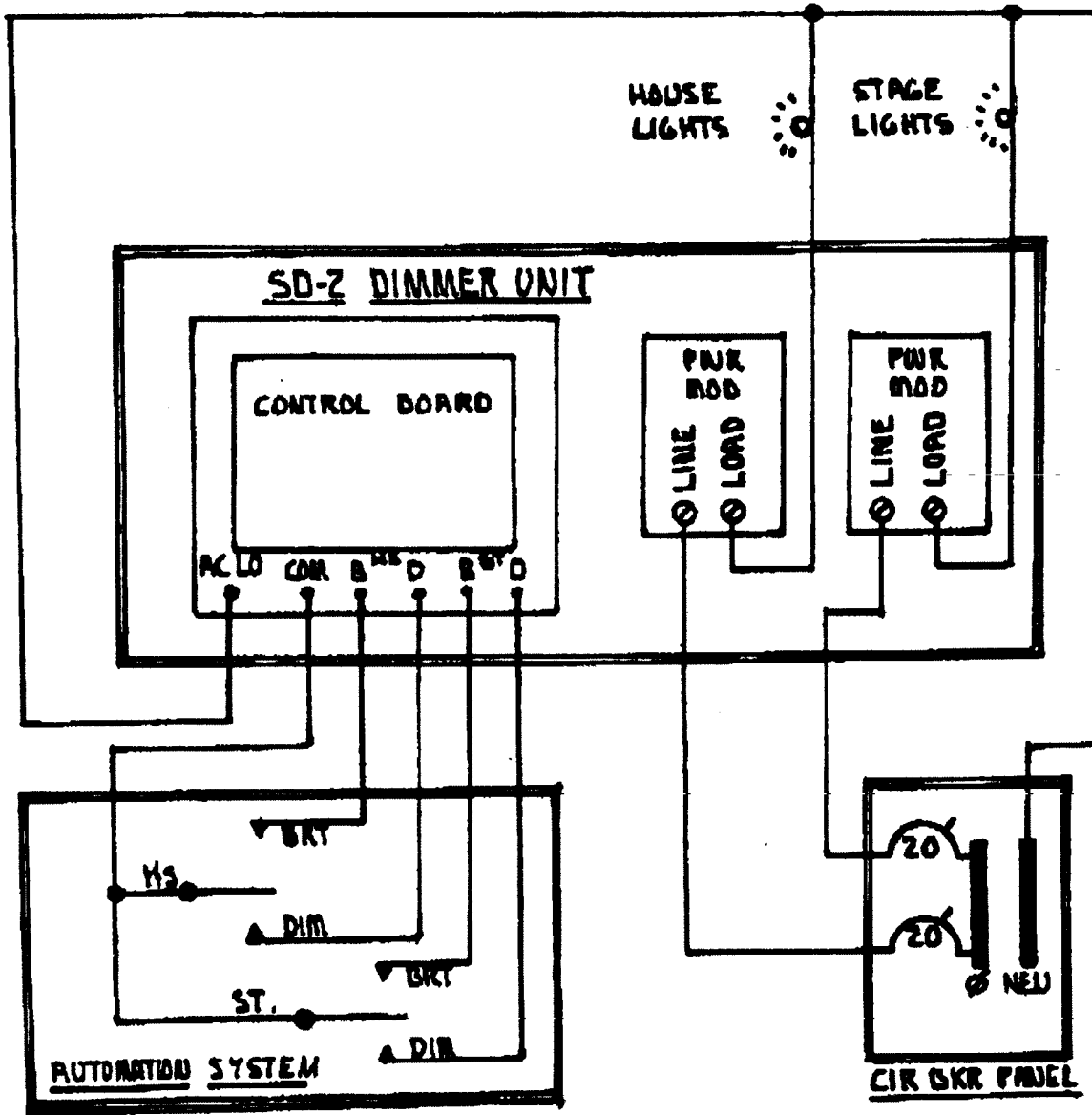

FIGURE 5.0



SYSTEM INTERCONNECT SCHEMATIC  
SPA-5(A) VERSION

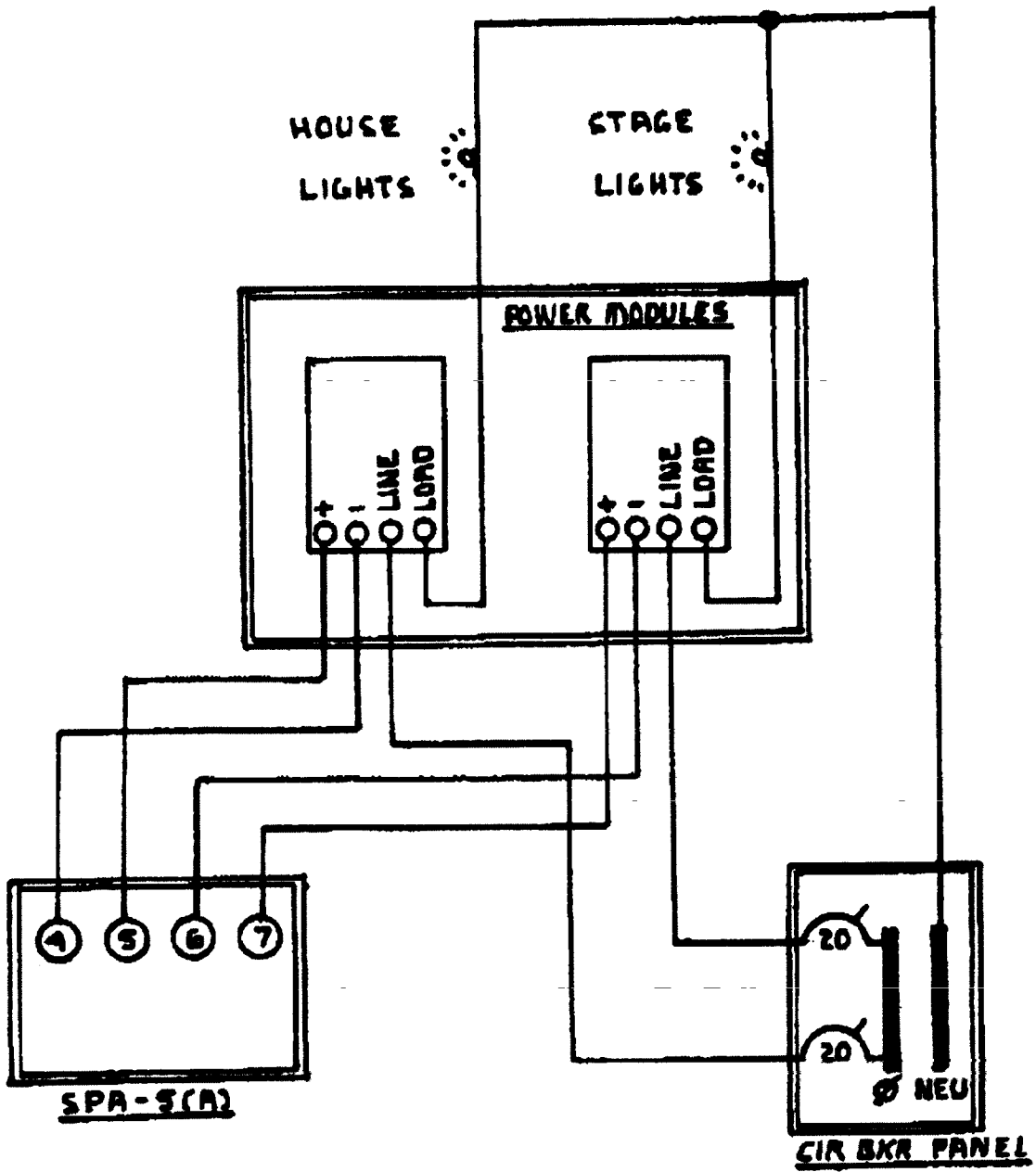
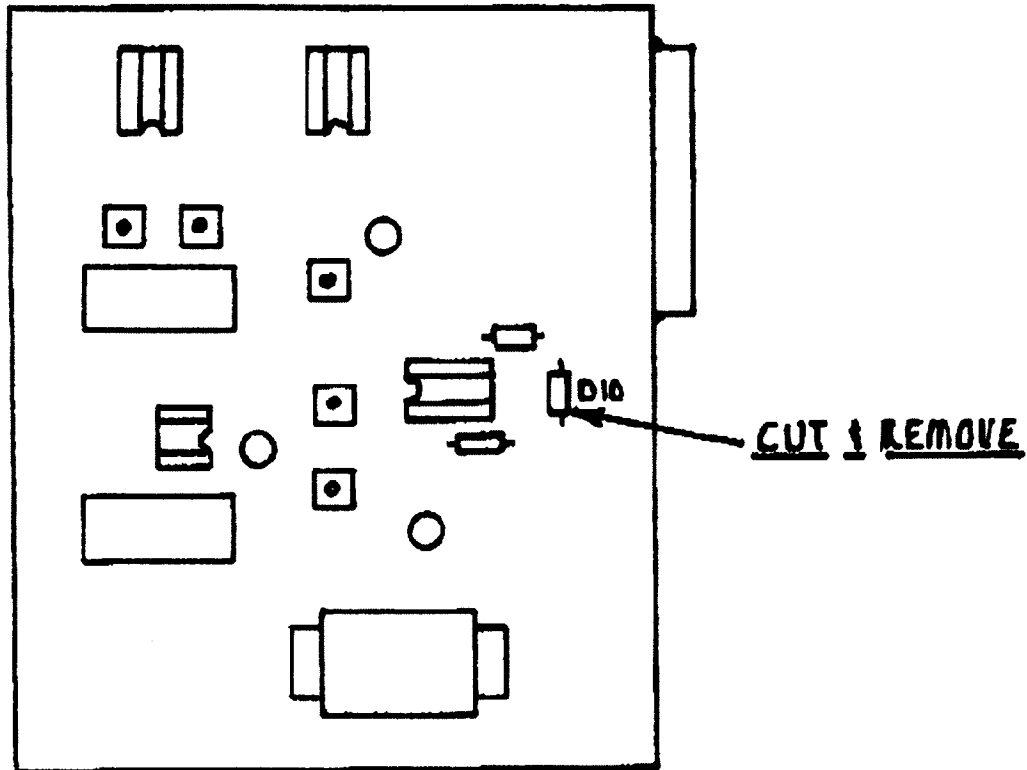

FIGURE 6.0

DISCREET CIRCUIT OPERATION



INSTRUCTIONS

- STEP #1 - CUT AND REMOVE DIODE (D10) FROM DIMMER CONTROL BD.
- STEP #2 - REMOVE 500K HALF LEVEL POTENTIOMETER FROM DIMMER CONTROL PANEL AND REPLACE WITH 50K ohm.
- STEP #3 - ~~THIS NEW POTENTIOMETER NOW CONTROLS THE HOUSE LIGHT BRIGHT LEVEL ONLY. THE STAGE LEVEL BRIGHT AND DIM LEVEL ARE CONTROLLED BY P-4 & P-5 ON THE DIMMER CONTROL BOARD.~~

APPENDIX 1.0

WIRING ADDITIONAL POWER MODULES

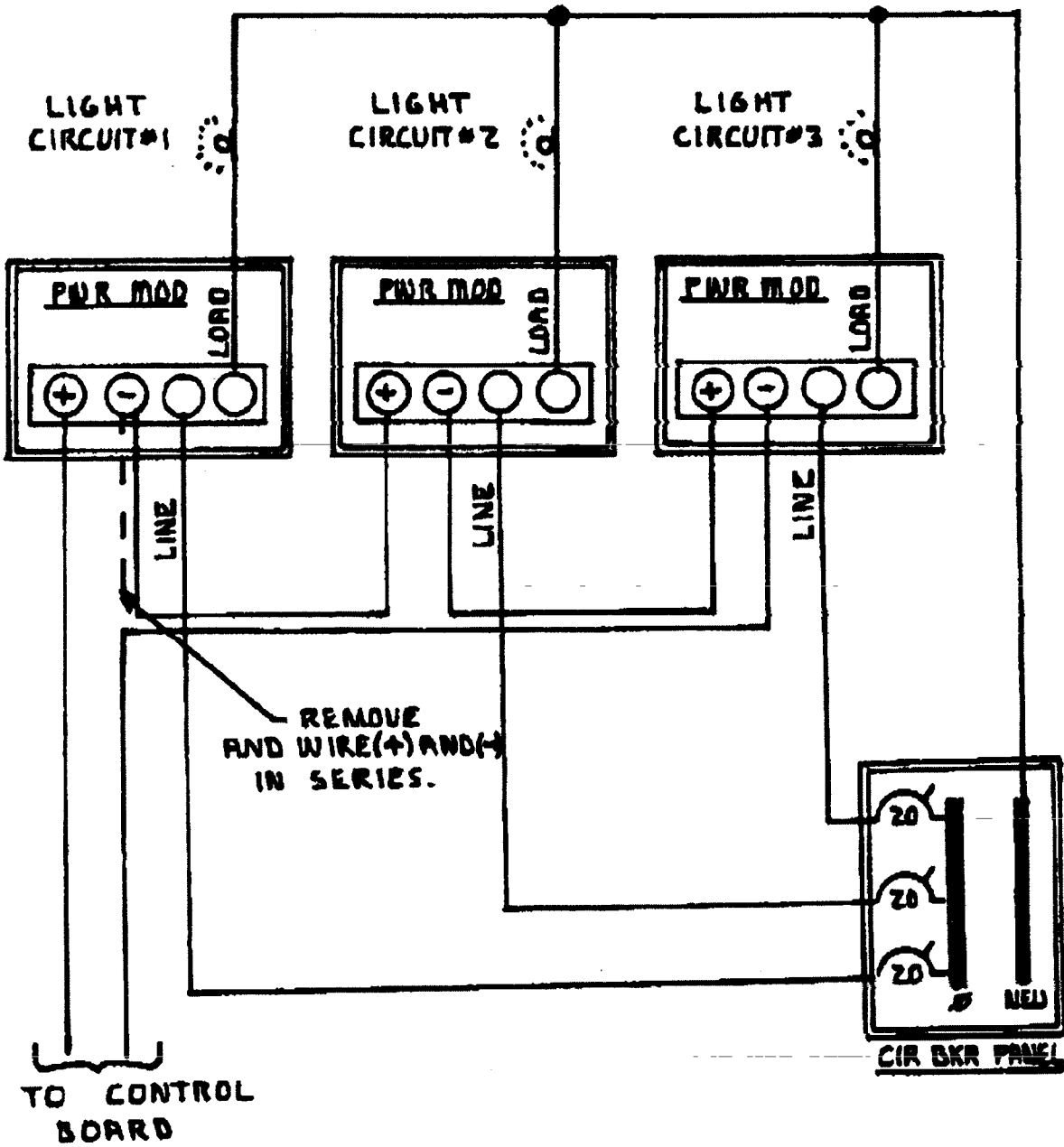

APPENDIX 2.0

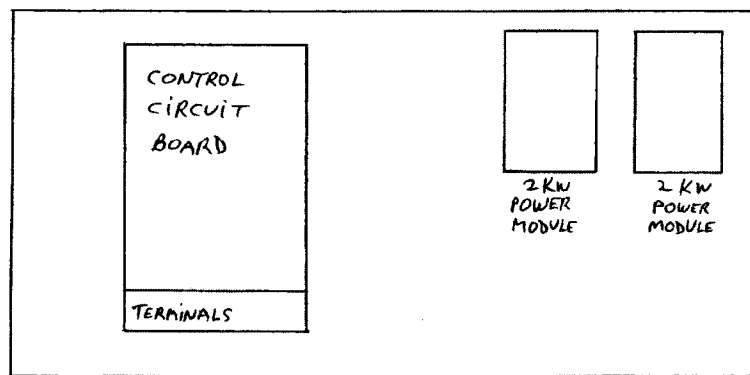
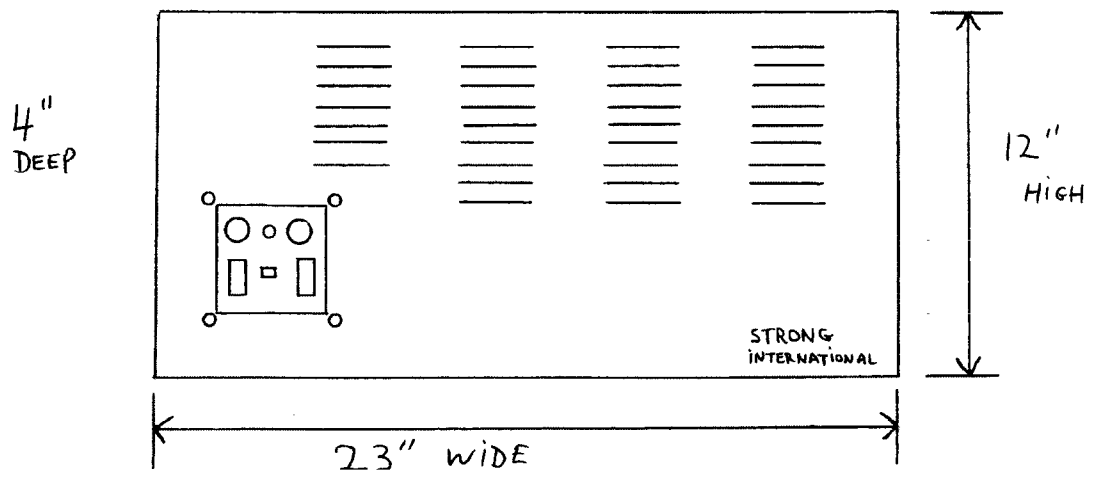

INTERIOR COMPONENT LAYOUT

# FRONT COVER CONTROL LAYOUT

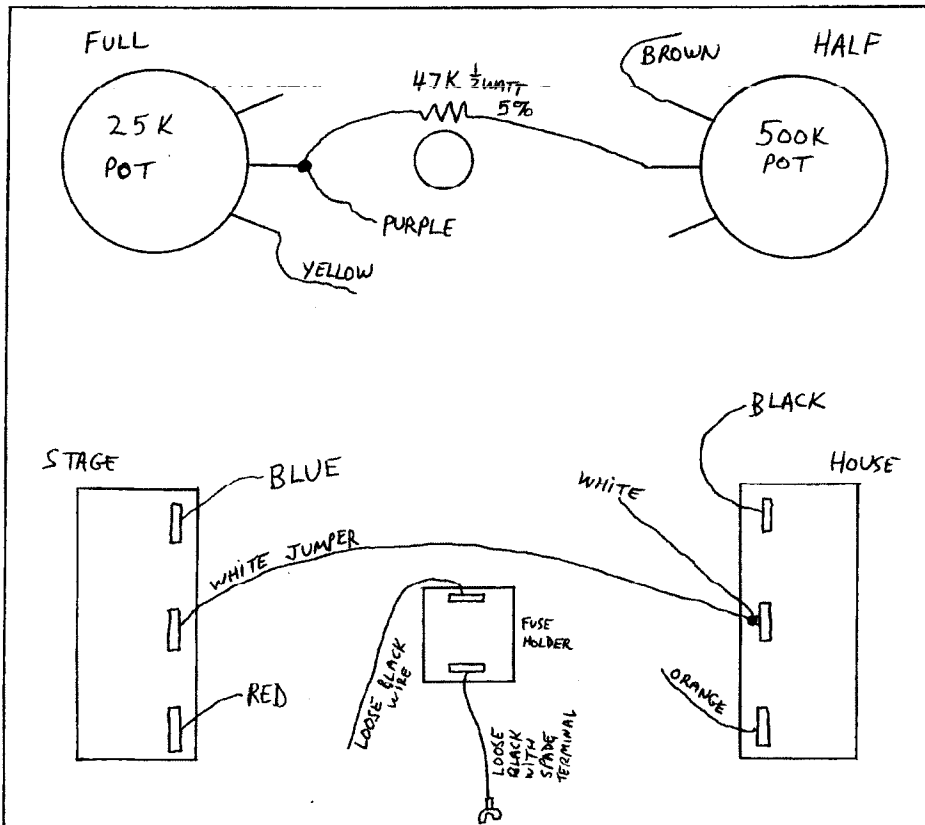
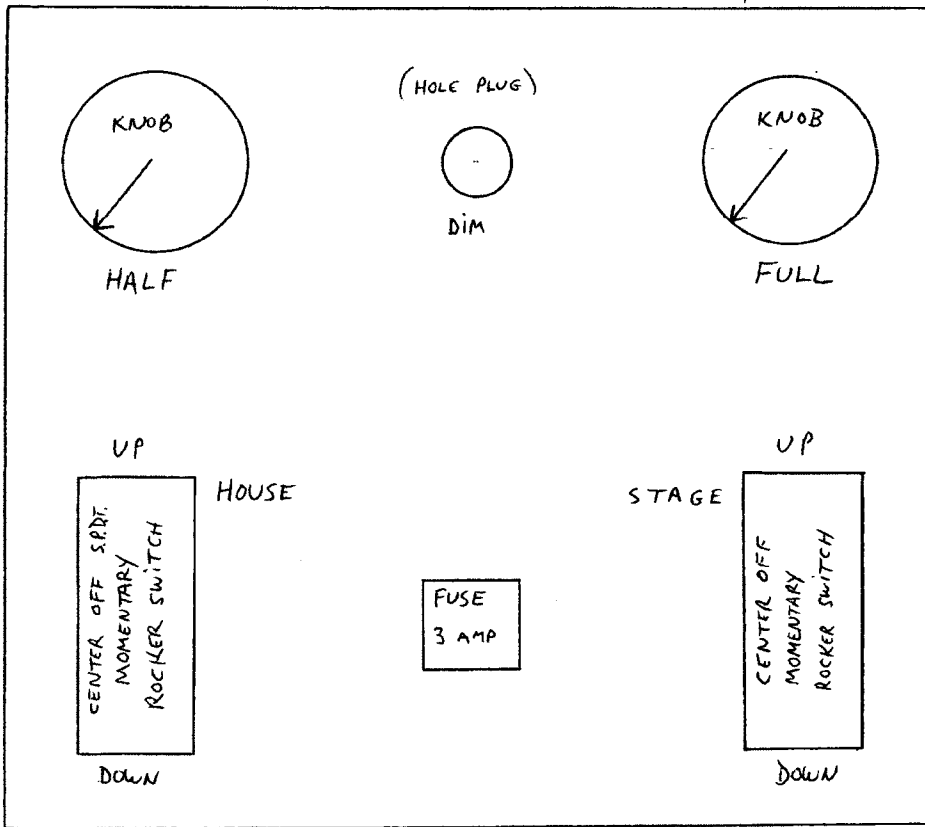

REAR VIEW OF CONTROLS SHOWING WIRING

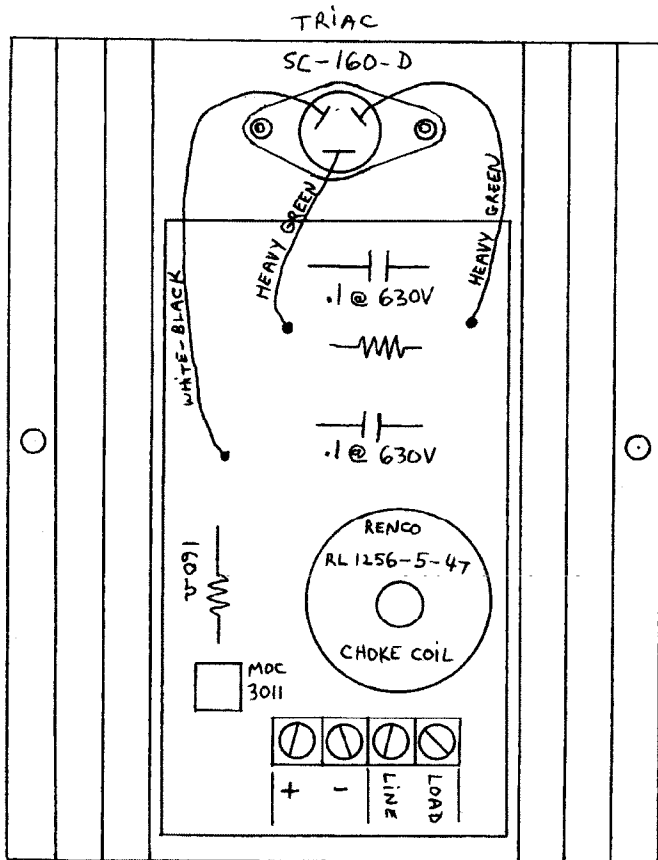

2 KW POWER MODULE

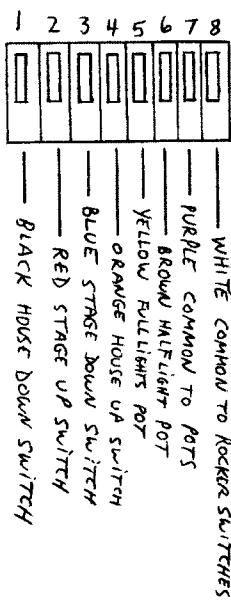

FLAT, WHITE MOLEX  
WAFER CONNECTOR

# DIMMER CONTROL BOARD

