

# Film-Tech

The information contained in this Adobe Acrobat pdf file is provided at your own risk and good judgment.

These manuals are designed to facilitate the exchange of information related to cinema projection and film handling, with no warranties nor obligations from the authors, for qualified field service engineers.

If you are not a qualified technician, please make no adjustments to anything you may read about in these Adobe manual downloads.

[www.film-tech.com](http://www.film-tech.com)

# *Instructions*

**FOR  
EQUIPMENT  
Type**

TROUPER

48000-7

49000-4

51000-4

10 - 57

Carbon Arc Follow Spotlight (AC Type)

**STRONG INTERNATIONAL, Inc.**  
4350 McKinley St. Omaha, NE 68112  
402/453-4444 FAX 402/453-7238 TELEX 484481

THE STRONG "TROUPER"  
HIGH INTENSITY  
SPOTLIGHT

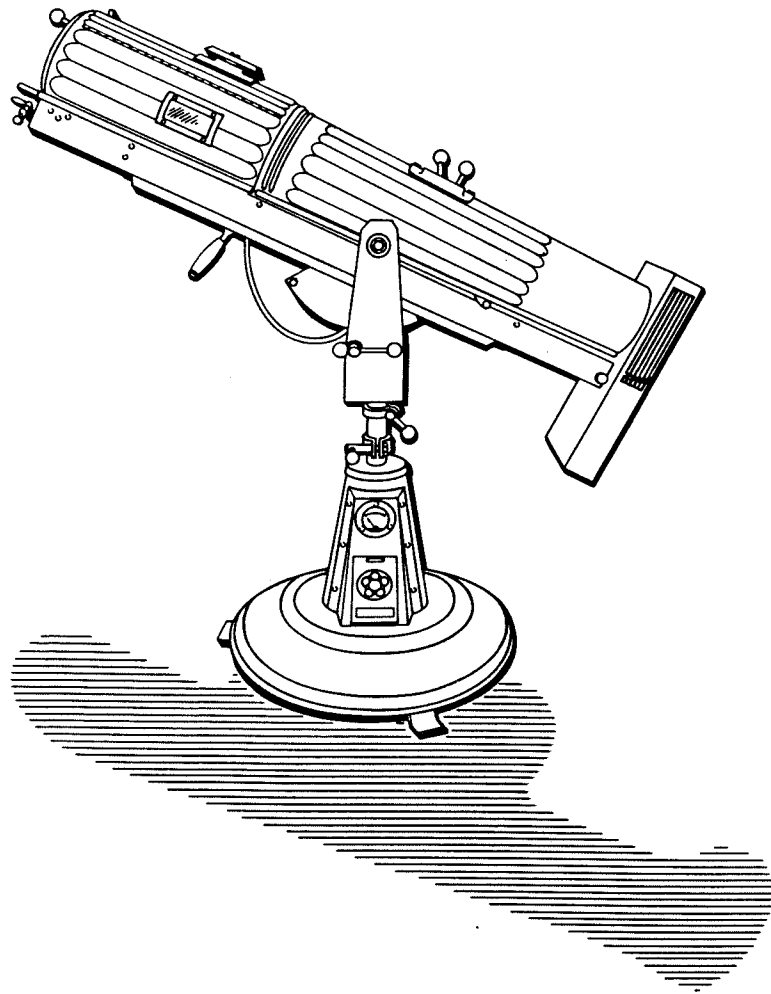

## PREFACE

THE STRONG TROUPER is a high intensity, reflector type alternating current follow spot and flood complete with automatic carbon arc lamp, variable focus projection optical system, a six color boomerang, flood masking device and a built-in transformer.

THE ELECTRICAL CONNECTIONS to this Trouper are made by simply plugging its power cord directly into any 115 volt, 60 cycle alternating current convenience outlet, since it draws only 10 amps from the line. Direct current must not be connected to this lamp because this will only blow out fuses or burn out the transformer.

THE CARBONS REQUIRED are 6mm x 7" high intensity A.C. copper coated projection carbons. The same size carbons are used in both the front and back carbon holders. The burning time for a single trim of carbons is one hour and twenty minutes. D. C. Suprex carbons are not suitable for use in this Strong Trouper.

POWER TO THE ARC is turned "On" and "Off" by the toggle switch near the rear top side of the lamphouse.

THE ELECTRICAL CAPACITY of this arc is limited to burn alternating current at 21 volts and 45 to 47 amperes, as supplied by the step down transformer mounted in the base of the pedestal.

THE EIGHT POSITION DIAL SWITCH on the side of the pedestal provides the means for manual compensation for commercial variations in the alternating current incoming line voltage. Set the switch at a position to supply 21 volts across the burning arc as indicated when the pointer is directly over the green line on the meter.

THREE SEPARATE UNITS, the arc lamp, the spot optical system and the pedestal, make up the spotlight assembly. Instructions covering each of these units is detailed under its separate heading.

THE TROUPER FOLLOW SPOT projects 6000 lumens of light.

IF AT ANY TIME you have a suggestion, or desire aid in securing anticipated results, please feel free to write directly to the personal attention of

*Harry H. Strong*

## SETTING UP SPOTLIGHT

TO UNPACK THE STRONG TROUPER SPOTLAMP open the boxes according to instructions by removing all screws only.

THE SPOTLIGHT BASE is setting on three casters for portability. If it is desired to have a more rigid mounting, the jack screws in the cloth bag stapled to the bottom of the box can be threaded into the three projecting feet, and adjusted until the weight has been shifted from the casters to the screws.

PREPARE TO PLACE THE LAMP AND OPTICAL ASSEMBLY on the base cradle assembly. First, however, make sure the horizontal swing lock lever, vertical tilt lock lever and the height adjustment clamp on the base is tightened.

MOUNT THE LAMP AND OPTICAL SYSTEM on the cradle with the braided connecting cord from the lamphouse directly above the electrical receptacle and jacks in the base yoke terminal box. Then fasten lamp and optical system to the base, using the four 5/16" x 18 cap screws furnished in the small cloth bag affixed to the yoke.

ATTACH THE BOOMERANG to the front of the optical system unit by inserting the hinge rod and securing with a cotter pin. Swing the boomerang into an upright position and secure the brace to the underside of the optical system pan by tightening the wing nut.

FASTEN THE RUBBER TILTING HANDLE, packed inside the lamp, to its proper position, a few inches aft of where the braided connecting cord projects through the lamphouse.

NOW CONNECT THE BRAIDED CONNECTING CORD from the lamphouse by plugging into the receptacle and jacks on the yoke terminal box. CAUTION: Be sure to turn the three prong twistlock plug to the right after inserting in the receptacle to lock.

THE ASH RECEIVER AND GLASS DEFLECTION SHIELD are packed inside the lamphouse. Attach the glass deflection shield to the ash receiver. Place the ash receiver in the lamphouse engaging the locating holes over the screw heads in base pan and with the glass deflector shield near the reflector.

TO ADJUST THE HEIGHT OF SPOTLIGHT, carefully check to make sure both horizontal swing and vertical tilt lock levers are tightened securely. Then insert the lever pin (with chain) into the height adjustment clamp and loosen: Caution: Make sure that there is a man at each end of the lamp to keep it from dropping. Adjust lamp to desired height and tighten clamp securely. CAUTION: Do not adjust height over 12" from minimum position.

PLATE 760

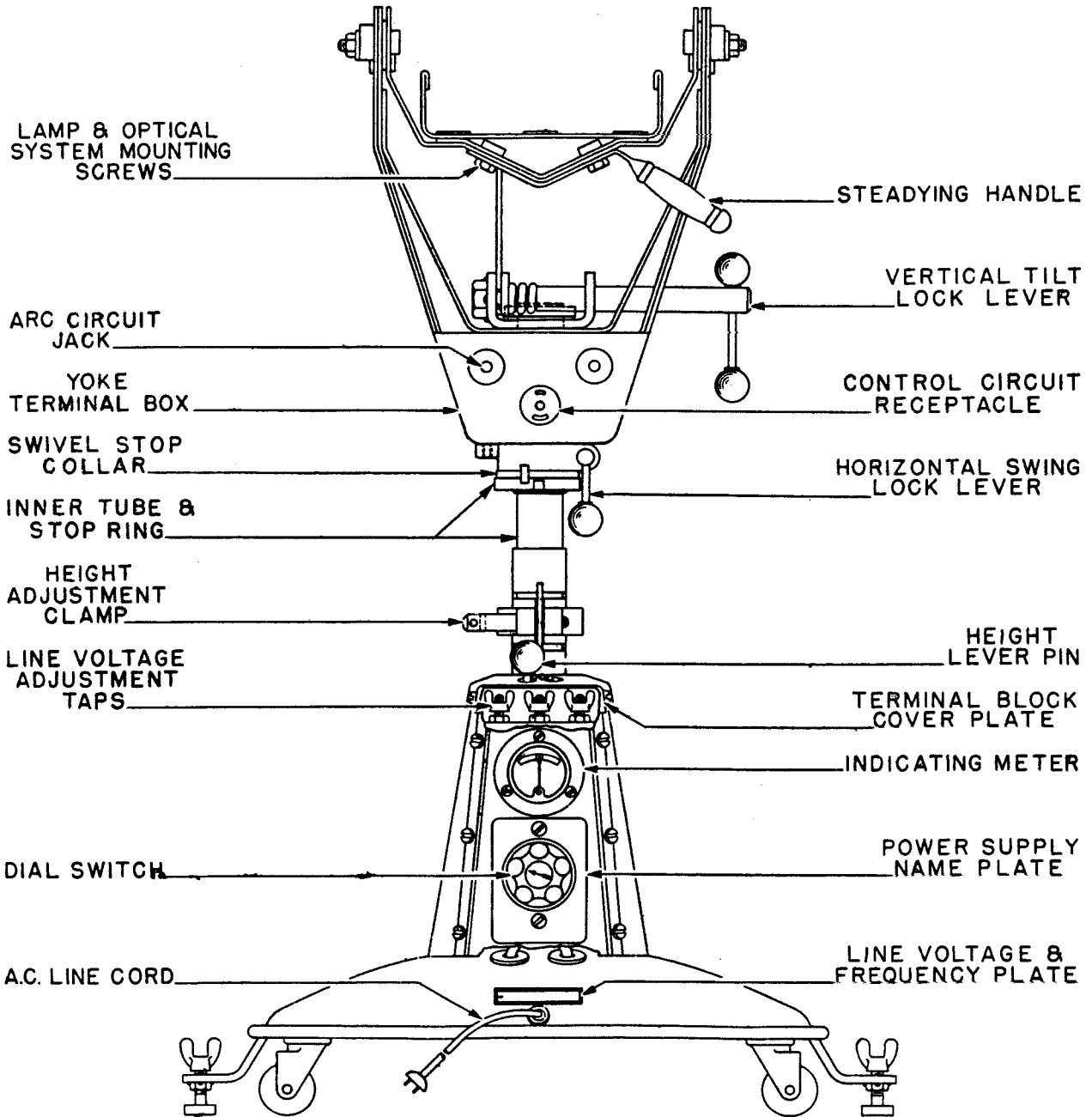

Plate 760

## OPERATION OF ARC LAMP AND POWER SUPPLY

THIS MOTOR DRIVEN ARC LAMP is designed to operate automatically with little attention from the operator. If these simple instructions are carefully followed, correct operation will result.

THE CORRECT LINE VOLTAGE AND FREQUENCY required for the power supply is engraved on a small nameplate near the line cord entrance to the spotlight base. The 115 volt models can be plugged into any A. C. convenience outlet which is fused for 15 amperes, first making sure that the line switch located in the top rear section of the lamphouse is in the "off" position.

THE 15 WATT TRIMMING LIGHT inside the lamphouse is automatically turned on when the lamphouse door is opened.

THE CORRECT CARBON TRIM for this lamp is a 6mm diameter, 7" long, special copper coated high intensity A. C. carbons, with a total burning time of 1 and 1/3 hours.

OTHER 6mm COPPER COATED CARBONS should not be used except in an emergency as incorrect burning will result.

TO TRIM THE LAMP, crank the ball crank in a counterclockwise direction until the carbon carriages are at their extreme distance apart. Depress the carbon release lever and insert each carbon until it is securely against the carbon stop, then release the lever so that the spring grips the carbon. Rotate the carbons in the jaws until they are in line with each other.

TO STRIKE THE ARC, close the lamphouse door and turn the line switch to the "on" position, turn the ball crank in a clockwise direction until the carbons touch; then quickly back the ball crank counter-clockwise until the arc gap is 1/4" long, as seen through the window. The correct gap is noted by observing that the images of the carbon tips on the arcoscope screen are the same distance apart as the black lines.

THE ARC FOCUS KNOB is a knurled collar located along side the ball crank and controls the position of the arc gap in relation to the focal point of the reflector. Turn the arc focus knob until the position of the imaged carbon tips coincides with the black lines on the arcoscope screen.



BURN THE ARC for two or three minutes, then manually adjust the arc gap length by means of the ball crank and position the arc gap by means of the arc focus knob so that the image of the carbon tips coincides with the lines on the arcescope screen.

CHECK THE POWER SUPPLY INDICATING METER to make sure the hand reads in the green zone. When the hand is in the center of the green zone, the correct power is being supplied to the arc, and the correct gap will be maintained.

TO RESTORE THE HAND TO THE GREEN ZONE, turn the transformer dial switch in the same direction that the meter hand needs to travel to return to the green zone. Quickly step the dial switch from one position to another to avoid extinguishing the arc.

IF THE HIGHEST POSITION NO. 8, is reached on the dial switch, and the meter hand is still to the left of the green zone, disconnect the line cord and remove the terminal block cover plate from the switch housing. Remove the line wire from the line voltage adjustment terminal block tap and connect to a tap of the next lower voltage marking.

IF THE LOWEST POSITION, NO. 1, is reached on the dial switch, and the meter is still to the right of the green zone, disconnect the line cord and remove the terminal block top cover plate from the dial switch housing. Remove the line wire from the voltage adjustment terminal block tap and connect to a tap of the next higher voltage marking.

BALANCING OF THE INTENSITY of top, bottom and sides of the projected spot is by means of the vertical and horizontal reflector tilt knobs located at the rear of the lamphouse.

THE ARCESCOPE MIRROR ADJUSTMENT has been set at the factory to give a clear brilliant projected spot when the carbon tips are imaged on the arcescope screen lines.

IF THE PROJECTED SPOT ON THE STAGE IS TOO YELLOW OR TOO BLUE it may be necessary to readjust the arc focusing knob to obtain a white spot. Then the arcescope mirror should be tilted to again bring the image of the burning carbon tips to coincide with the black lines on the arcescope screen.

THE ASH RECEIVER which receives the drippings from the arc and the glass deflector shield which projects the reflector is removable for cleaning, but must not be left out of position when the carbons are burning.

PLATE 887

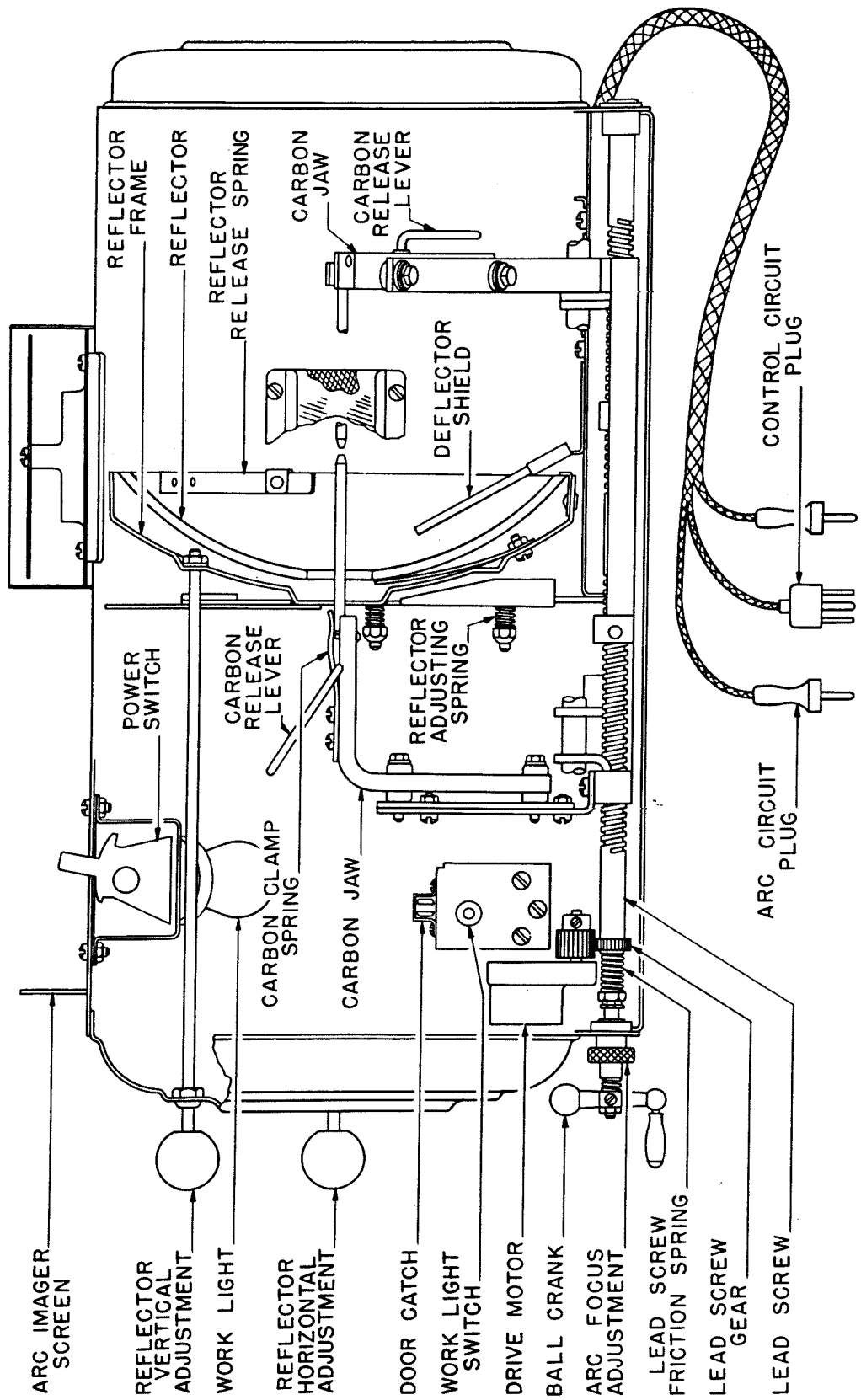

181

## OPERATION OF OPTICAL SYSTEM

THE APERTURE SELECTOR is the front lever which projects through the top of the optical system housing. When this lever is to the left, looking at the spotlamp from the rear, the largest aperture is obtained. Smaller apertures are obtained as the lever is moved to the right.

THE SPOT SIZE CONTROL handles are located on each side of the optical system just above the base pan. A variation of spot sizes in a ratio of 7 to 1 can be obtained with the movement of the spot size control from one extreme to the other.

THE MAXIMUM FLOOD SPOT is obtained with the aperture selector lever to the left for the large aperture and with the spot size control handle moved as far as possible toward the rear.

SMALLER SIZED SPOTS are projected as the spot size control handle is moved forward. Most of the spot sizes needed will be produced with the large aperture.

FOR A "HEAD SPOT" or any spot size smaller than can be obtained with the spot size control handle in its extreme forward position, shift the aperture selector lever to the right, for a smaller aperture. The aperture selector lever should always be returned to its extreme left position before the spot size control handle is again moved to obtain larger spots.

THE MASKING SHUTTER LEVER and dowsers is the rear lever projecting through the top of the optical system housing. The masking shutter blades are operated by this lever to shape the projected spot to a rectangular or strip spot.

THE DISENGAGED POSITION of the masking shutter lever is to the extreme right and varying degrees of masking to complete cutoff are obtained by moving the lever to the left.

THE SPOT FOCUSING CONTROL is located on the side of the optical system base pan, just behind the boomerang, and is used to adjust the optical system for the length of throw. When making an adjustment the aperture selector handle should be to the left and the spot size control handle moved about 5" from the extreme front position; then rotate the spot focusing control until the sharpest edge is obtained on the projected spot.

PLATE 1781

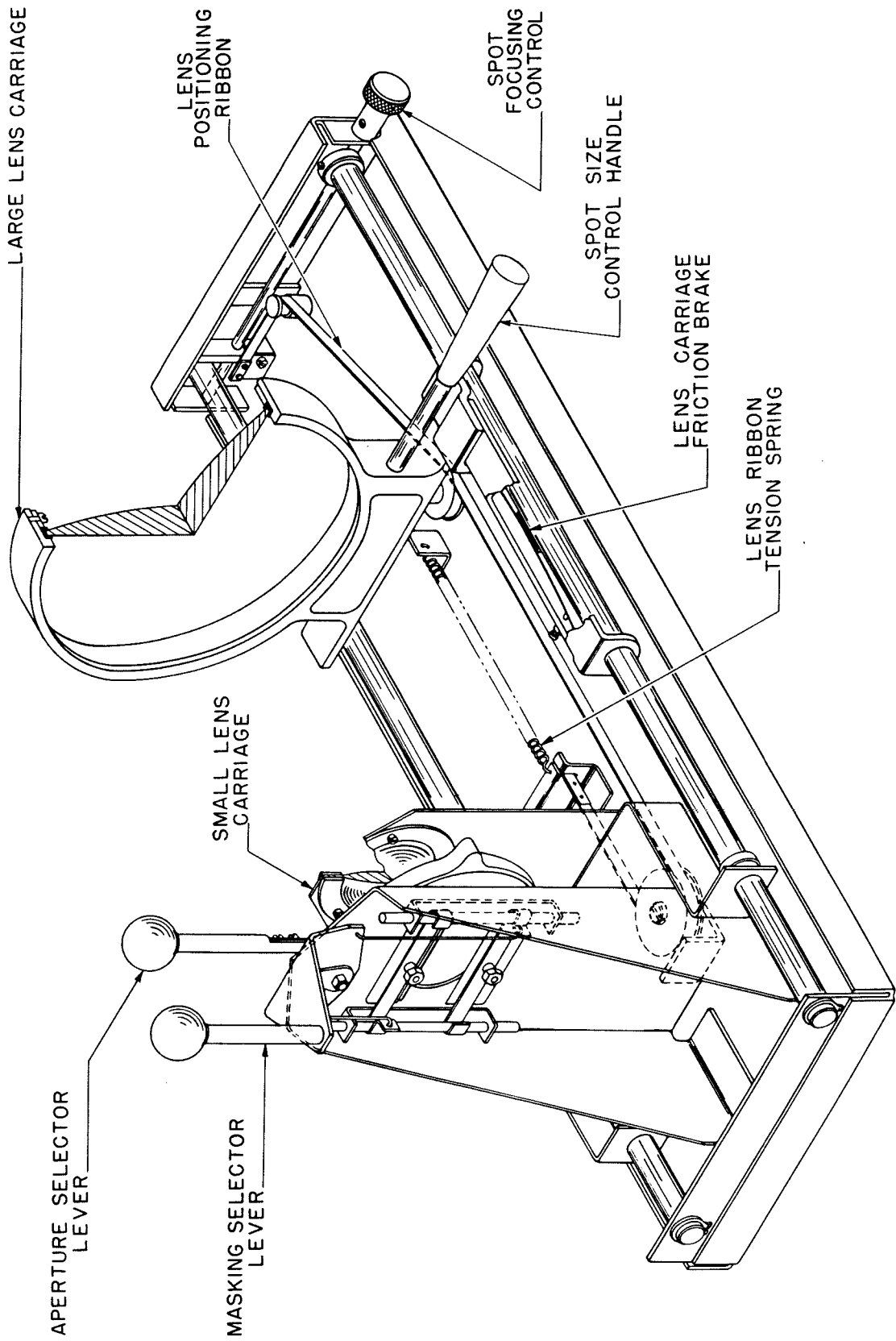

Plate 1781

## HANDLING THE SPOTLIGHT

GENERALLY THE BEST POSITION FOR OPERATION is to stand at the center of the spotlamp, on the right hand side, although angle of tilt and size of porthole may alter the position for most convenient and effortless operation.

ONE HAND SHOULD BE KEPT ON THE SPOT SIZE SELECTOR handle as the spot can thus be both directed and changed in size instantly.

THE OTHER HAND generally is used for operating the aperture selector lever, masking shutter lever, boomerang and steadying the spotlight.

THE HORIZONTAL SWING LOCK LEVER and vertical tilt lock lever located in the base column assembly can be set to give the required amount of friction; on the spotlamp swing, to suit the individual operator.

## OPERATION OF COLOR BOOMERANG

THE COLOR BOOMERANG is equipped with 6 color filters and a special attachment for holding an ultra-violet filter or an extra color slide.

TO OPERATE INDIVIDUAL COLOR FILTERS, raise the desired filter pull to the uppermost position. A permanent magnet located in the top of the color box holds the filter in position.

TO RELEASE A COLOR, gently push the filter pull downward until it disengages from the magnet, and let it fall in place.

TO REMOVE A FILTER HOLDER for inserting a filter, open the top of the color box. Raise the desired slide and lift out the filter holder.

GELATINE FILTERS cut to 9-1/4" x 9-1/2" are required and are inserted in the envelope and fastened by the cover plate. Return the filter holder to its proper position in the slide and close the color box.

FOR IDENTIFICATION of filter pulls, fasten a small strip of gelatine to the filter pull handle.

VARIOUS ULTRA-VIOLET FILTERS, or extra filter holders are accessories and can be obtained through your dealer or directly from Strong Electric Corporation.

TO REMOVE OPTICAL SYSTEM HOUSING AND ADJUST  
ANGULARITY OF MASKING SHUTTER BLADES

AN UNBALANCED CONDITION will occur when the optical system housing is removed, therefore the vertical tilt lock lever should be snugly tightened.

POSITION THE LARGE LENS in flood position by sliding the spot size control handle to its extreme rear position.

REMOVE THE LENS ACCESS HOLE COVER by loosening the two knurled screws holding it and removing the knob from the masking shutter lever.

THE OPTICAL SYSTEM HOUSING may now be removed by loosening, but not removing, the three knurled screws holding the housing to the lamphouse and the single knurled screw holding the forward end of the housing. Then slide the optical system housing forward until it disengages the lamphouse and lift upward and off.

THE ANGULARITY OF THE MASKING SHUTTER BLADES is adjusted to compensate for the horizontal projection angle by removing the optical system housing and lamp nose cone. Loosen the knurled screw holding each of the masking shutter blades and angle the bottom blade so that it lies parallel with the footlights; then tighten in place with its knurled screw.

OPERATE THE MASKING SHUTTER LEVER to close the shutter blades and cause the upper blade to line up in the proper position. Tighten the upper blade knurled retaining screw.

CHECK THE SETTING by striking the arc and projecting a narrow strip spot to the stage.

## TO CLEAN REFLECTOR AND LENS

THE REFLECTOR SHOULD BE CLEANED OFTEN. Do not allow any black or white soot to collect on the reflector. This will prevent cracking of the reflector and insure a white spot with very little discoloration on the sides.

TO MINIMIZE THE POSSIBILITY OF BREAKING THE REFLECTOR. When the spotlight is operated at a negative angle place the reflector in its' holder so that the notch in the reflector is at the side. DO NOT place the reflector in holder so that the notch is at the top.

TO CLEAN THE SMALL LENS, remove the lens access hole cover then use a good grade of alcohol and a piece of lens tissue (facial tissue can be used as a substitute), gently wipe both sides of the lens until a clean surface is obtained.

THE BACK SURFACE OF THE LARGE LENS can readily be cleaned by using the same access hole as above, with the large lens carriage in the rear position.

TO CLEAN THE FRONT SURFACE OF THE LARGE LENS, slide the lens carriage to the full forward position. The front surface is now readily accessible through the front of the housing.



## TROUBLE CHART

### TROUBLE: REFLECTOR BREAKAGE

- (1) **PROBABLE CAUSE:** Excessive soot or white scum. If products of combustion such as black soot or white scum are allowed to remain on the reflector, they will absorb instead of reflect the heat from the arc. This results in cracking the glass, deteriorating the silver and blistering the backing.

**REMEDY:** Cleaning the reflector should become a daily habit which the projectionist follows religiously. Cleaning does not mean simply wiping off the reflector occasionally; it means actually polishing the reflector every day with a soft cloth to maintain the bright optical surface of the glass. The white scum if allowed to remain, soon burns itself into the surface of the glass. It can only be scoured off by considerable polishing with Bon Ami used on a slightly moistened cloth. Any large particles which adhere to an old reflector may be removed with a flexible razor blade.

PLATE 764

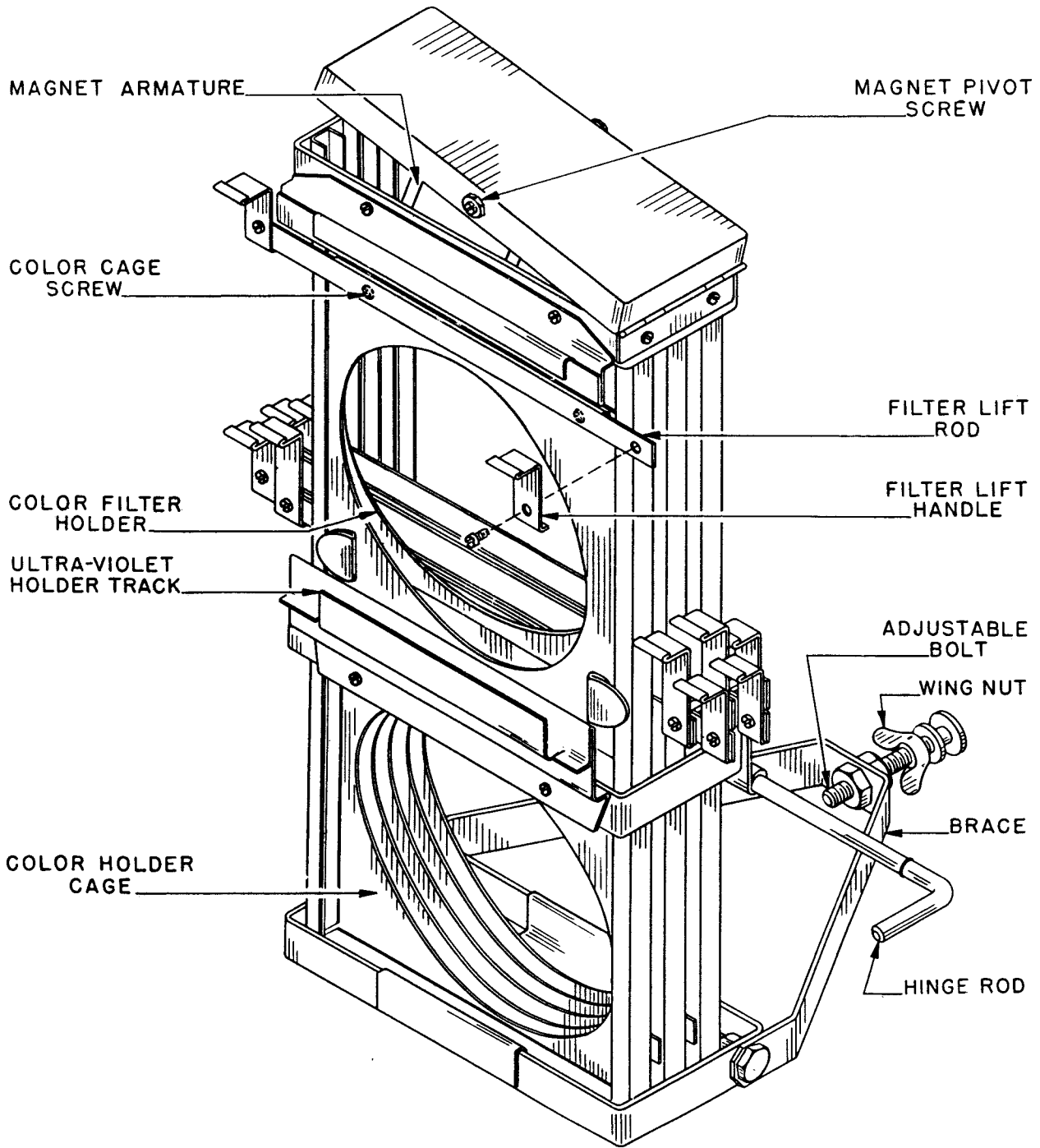

Plate 764

PLATE 1392

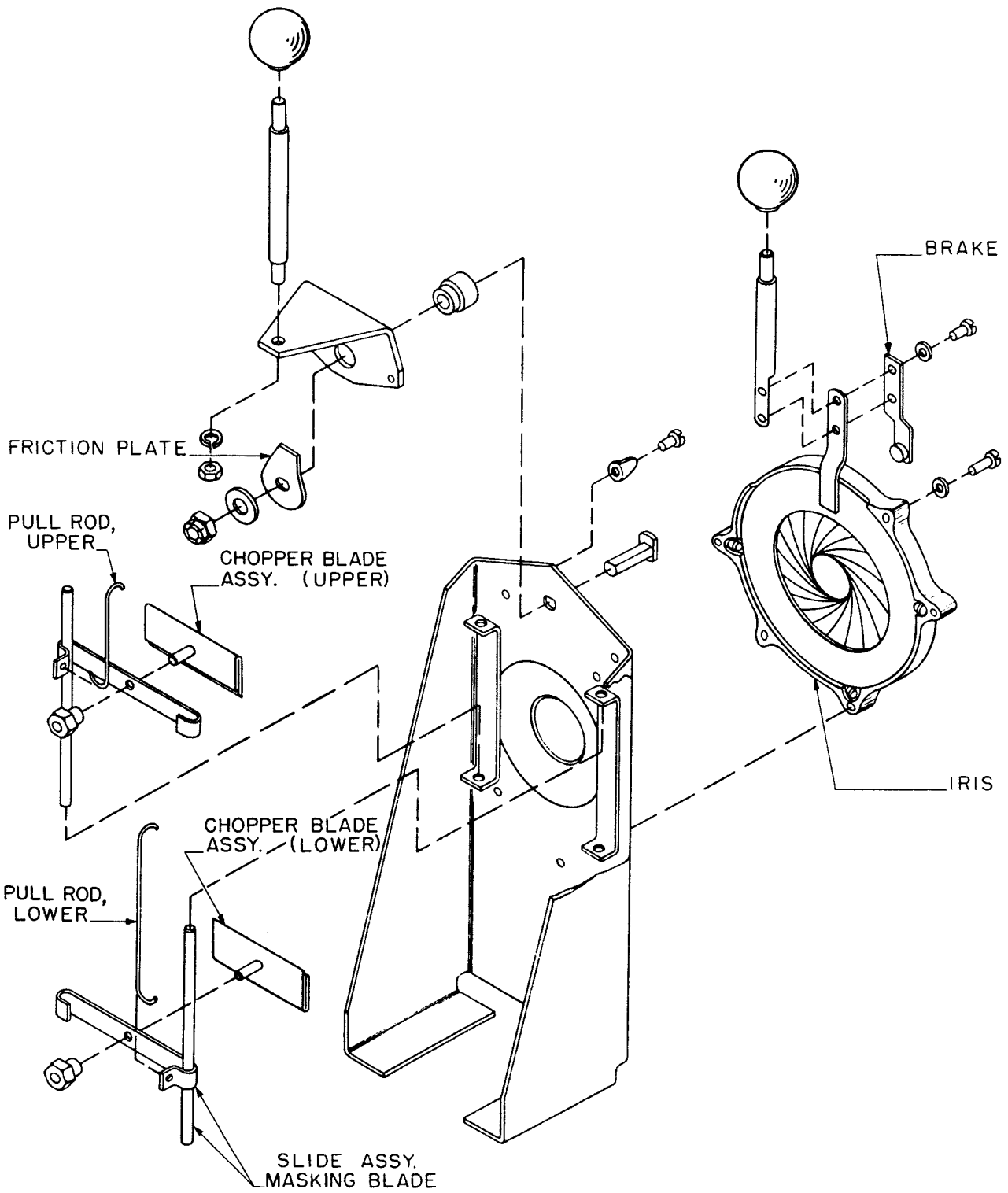

Plate 1392

WIRING DIAGRAM  
NUMBER 743

CONTROL CIRCUIT  
RECEPTACLE

ARC CIRCUIT  
JACK

ARC CIRCUIT  
JACK

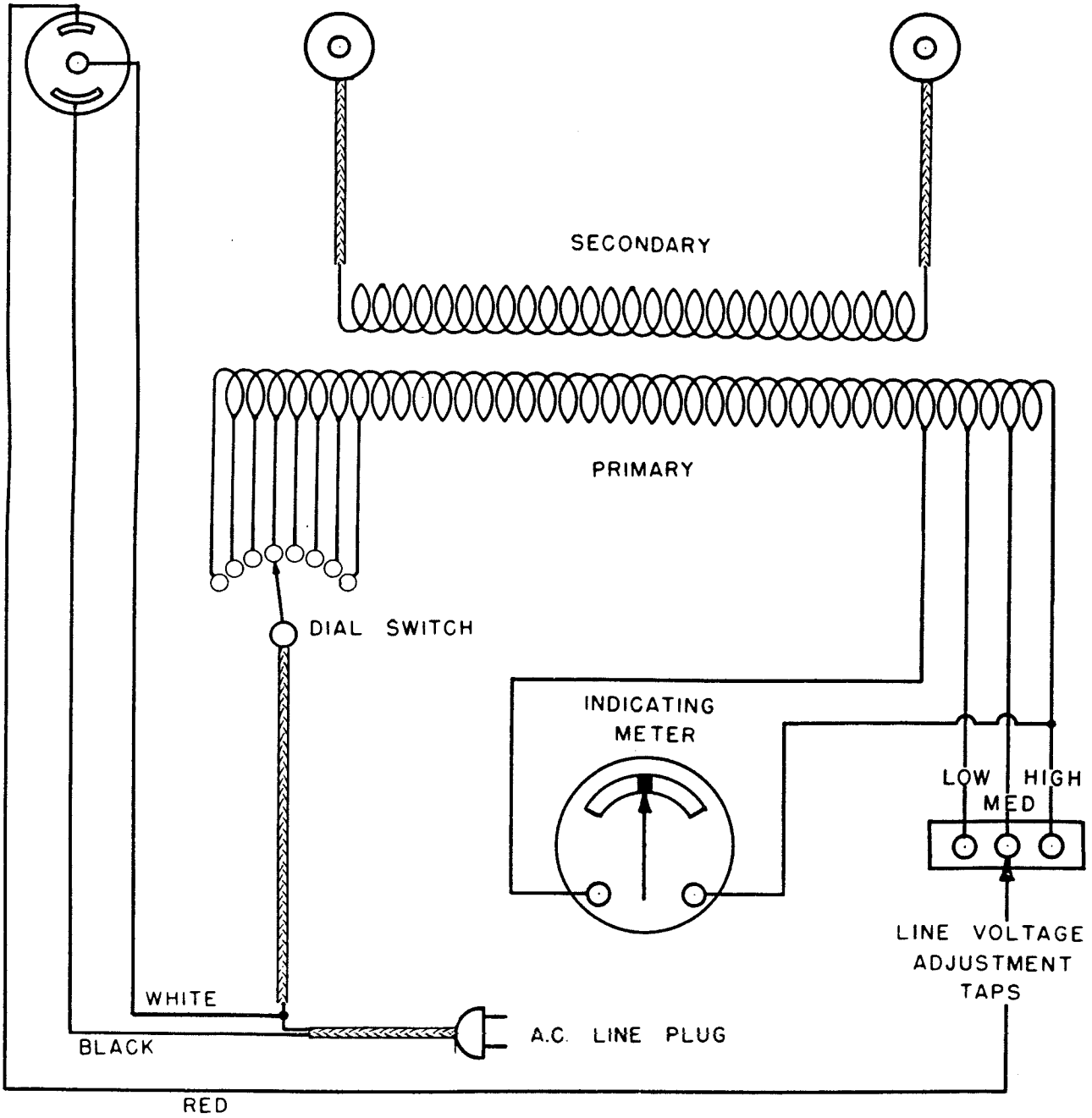

Plate 743

WIRING DIAGRAM  
NUMBER 816

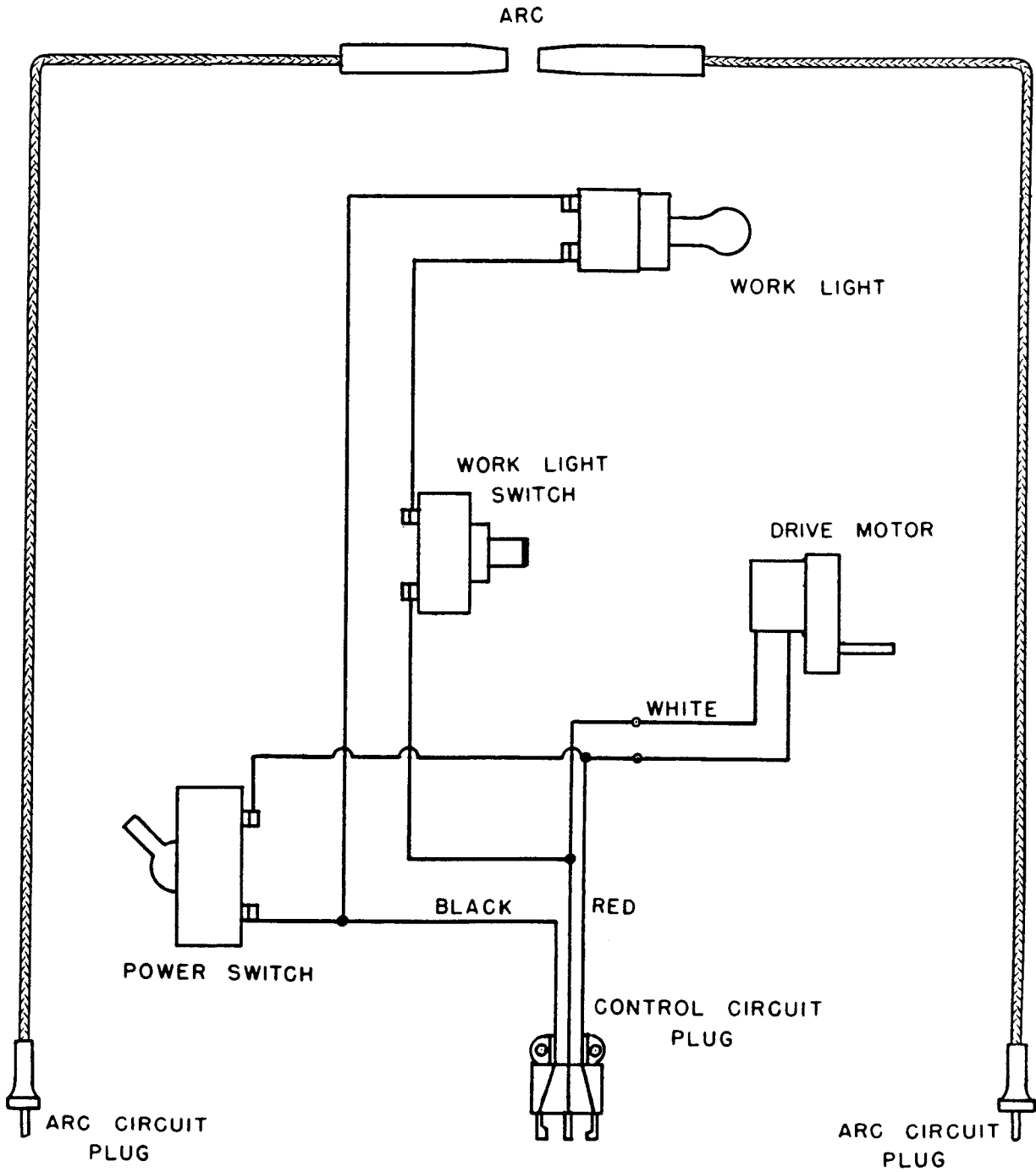
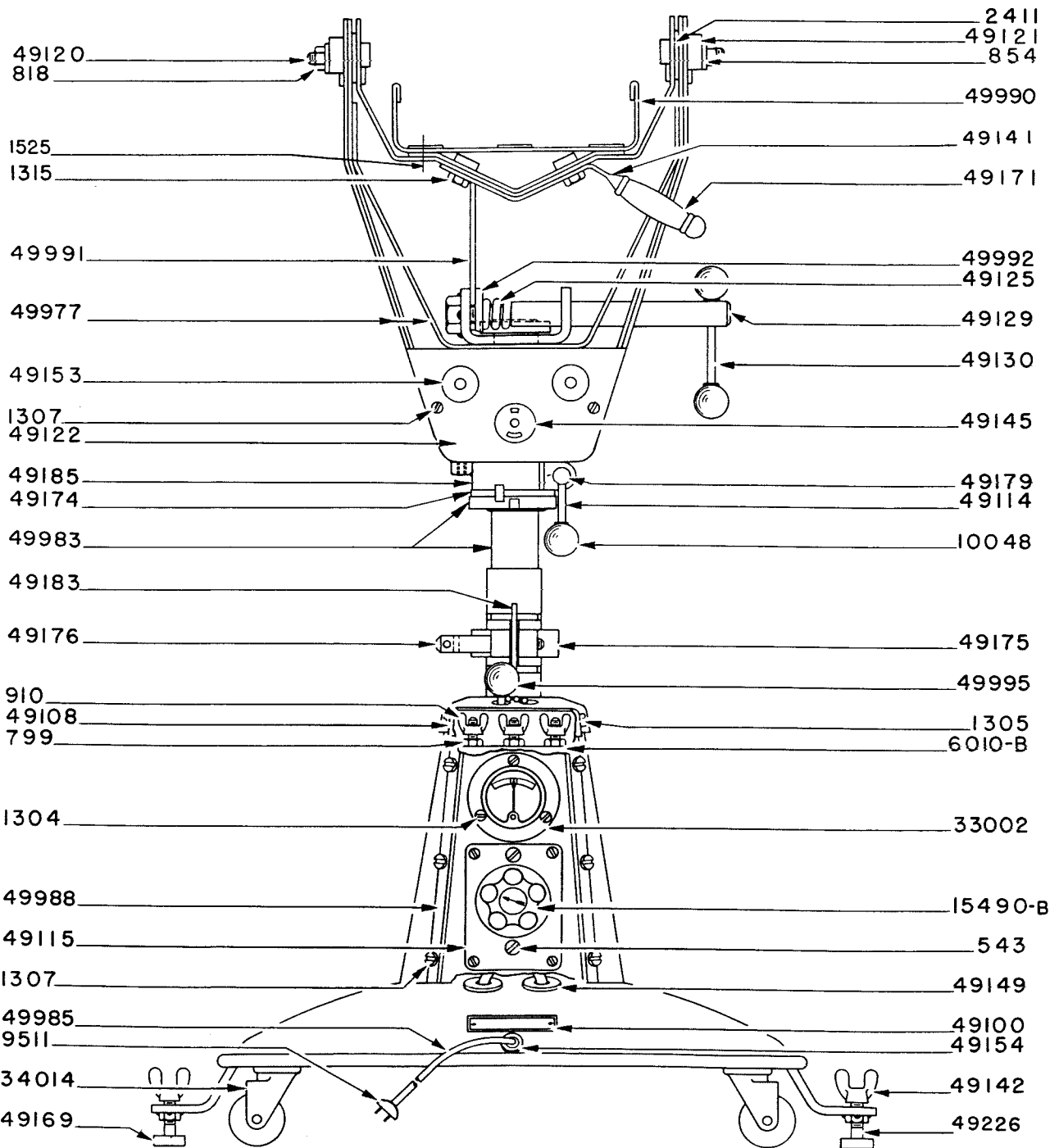
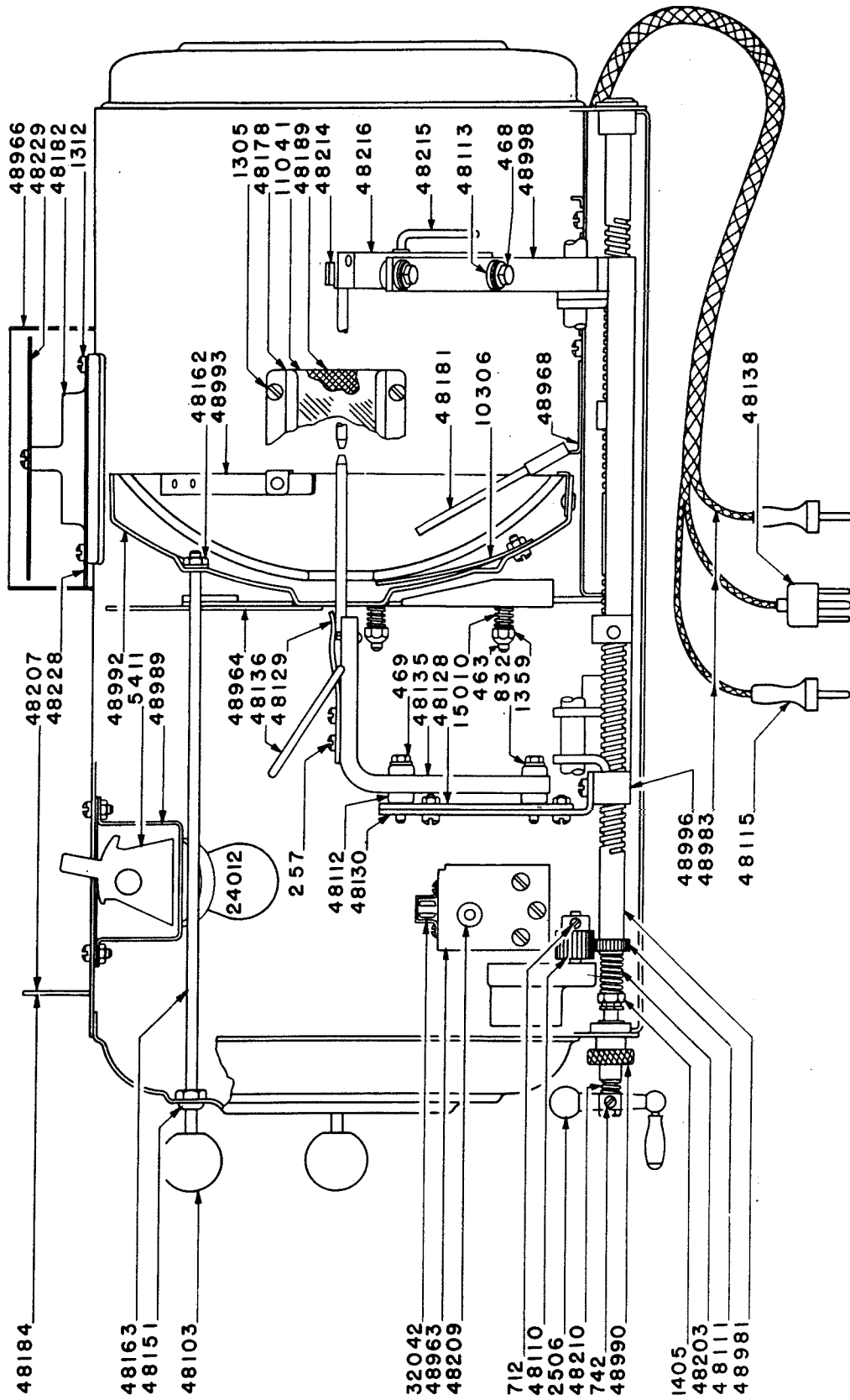

PLATE 1784



543	Screw 1/4-20 x 3/8 Bind. Hd.
799	Nut #10-24 Hex Brass
818	Nut 3/8-16 Hex
854	Washer 3/8" Flat
910	Wing Nut #10-24
1304	Screw #8-32 x 5/16" Bind. Hd.
1305	Screw #6-32 x 1/4" Bind. Hd.
1307	Screw #10-32 x 3/8" Bind. Hd.
1315	Screw 5/16-18 x 5/8" Hex. Hd.
1525	Thumb Screw 5/16-18 x 3/4"
2411	Washer
9511	Cord Cap
10048	Knob - Black
15490-B	Dial Switch Assembly
15492	Handle and Shaft Assembly - Dial Switch
33002	Meter
34014	Caster
49100	Line Voltage Plate (Instructions)
49108	Cover - Meter & Switch Housing
49114	Handle Stud
49115	Name Plate
49120	Bolt - Tilt Axis
49121	Washer - Tilt Axis
49122	Cover Plate - Receptacles
49123	Cover Plate - Rear
49125	Spring - Tilt Clamp
49129	Clamp Shaft - Tilt
49130	Handle - Tilt Clamp
49141	Handle
49142	Wing Nut 1/2-13
49145	Twistlock Base (Hubbell #7487)
49148	Rubber Grommet
49149	Rubber Grommet
49153	Female Jack
49154	Bushing - A. C. Lead Cord
49169	Rubber Cap
49171	Handle Grip - Operating
49175	Clamp Collar - Height Adjustment
49176	Clamp Bolt
49179	Nut
49185	Clamp Collar - Horizontal Swing
49226	Adjustable Foot
49977	Pedestal Saddle Assembly
49985	A. C. Lead Cord Assembly
49988	Cover Plate Assembly - Meter and Switch
49990	Lamp and Lens Table Assembly
49991	Yoke and Quadrant Plate Assembly
49992	Tilt Clamp Plate and Button Assembly
49995	Handle Assembly - Height Clamp

PLATE 889





120	Screw #4-36 x 1/8" Fil. Hd.
179	Screw #6-32 x 1/4" Fil. Hd.
180	Screw #6-32 x 5/16" Fil. Hd.
187	Screw #6-32 x 1" Fil. Hd.
254	Screw #8-32 x 1/4" Fil. Hd.
257	Screw #8-32 x 7/16" Fil. Hd.
463	Screw #10-24 x 1-5/8" Oval Hd.
468	Screw #10-32 x 7/8" Hex Hd.
469	Screw #10-32 x 1-1/4" Hex. Hd.
712	Set Screw #8-32 x 1/4" Cup Pt. Headless
742	Set Screw 1/4-28 x 5/16" Dog Pt. Headless
832	Washer #10 Flat
885	L'Washer #10 Shakeproof
892	L'Washer #6 Shakeproof
1254	Terminal #24 Sherman
1312	Screw #8-32 x 1/2" Bind. Hd.
1359	Nut #10-24 Dualock
1405	Locknut 5/16-24
1972	Imager Reflector Assembly
2505	"D" Washer - Brass
2506	Ball Crank Assembly
4141	Reflector (10-1/4 x 3-1/4 x 24) ✓
5411	Power Switch
10066	Receptacle, Pilot Light
10306	Tension Spring, Reflector
10317	Sleeving for #10306
11041	Window Glass
11119	Wire Clamp
15010	Spring, Reflector Adjusting
24012	Pilot Light
32042	Door Catch
32043	Striker, Door Catch
48103	Knob, Ref. Adjusting
48105	Name Plate
48110	Motor Gear
48111	Lead Screw Gear
48112	Lava Bushing
48113	Lava Bushing
48127	Truarc Ring #5100-56
48128	Plate, Rear Jaw Adjusting
48129	Spring, Rear Jaw
48130	Bracket, Rear Jaw Support
48135	Jaw, Rear Carbon
48136	Release Lever, Rear Carbon
48138	Cord Cap, Twistlock
48146	"D" Washer, Steel
48150	Bushing, Lead Wires
48151	Bushing, Ref. Adjusting Rods

48152 Slide Rods, Carriages  
48155 Male Plug  
48161 Drive Pin, Carbon Carriages  
48162 Button, Adjusting Rods  
48163 Rods, Reflector Adjusting  
48178 Retainer, Window Glass  
48180 Drive Motor (115 V. - 60 cyc.)  
48181 Deflector Shield, Reflector  
48182 Vent Casting  
48184 Frame, Arc Imager  
48189 Screen, Window Glass  
48191 Spacer, Lead Screw & Carriage  
48192 Spacer, Slide Rods & Carriages  
48203 Spring, Lead Screw Tension  
48207 Imager Card  
48209 Switch, Pilot Light  
48210 Spring, Focusing Knob Tension  
48211 Spacer, Ball Crank  
48212 Insulation, Power Switch  
48214 Spring, Front Jaw  
48215 Lever, Front Carbon Release  
48216 Jaw, Front Carbon  
48217 Drive Motor (230 V. - 50 Cyc.)  
48218 Drive Motor (230 V. - 60 Cyc.)  
48219 Drive Motor (115 V. - 50 Cyc.)  
48220 Drive Motor (115 V. - 25 Cyc.)  
48228 Vent Casing Plate  
48229 Baffle Plate, Vent  
48962 Door Assembly  
48963 Bracket Assy., Door Latch & Switch  
48964 Reflector Carriage Assembly  
48965 Light Cone, Lamp  
48966 Vent Casing Assembly  
48968 Auxiliary Ash Pan Assembly  
48973 Front Jaw Assembly  
48974 Lead Screw Unit Assembly  
48975 Rear Jaw Assembly  
48981 Lead Screw & Stud Assembly  
48983 Cable Assembly, Lamp to Receptacle  
48989 Bracket Assy., Power Switch & Receptacle  
48990 Knob & Bearing Assembly  
48991 Bracket Assy., Motor Support  
48992 Reflector Frame Assembly  
48993 Spring Assembly, Reflector Clamp  
48995 Rear Carriage Assembly  
48996 Rear Carriage, Welded Assembly  
48997 Front Carriage Assembly  
48998 Front Carriage, Welded Assembly

PLATE 1783

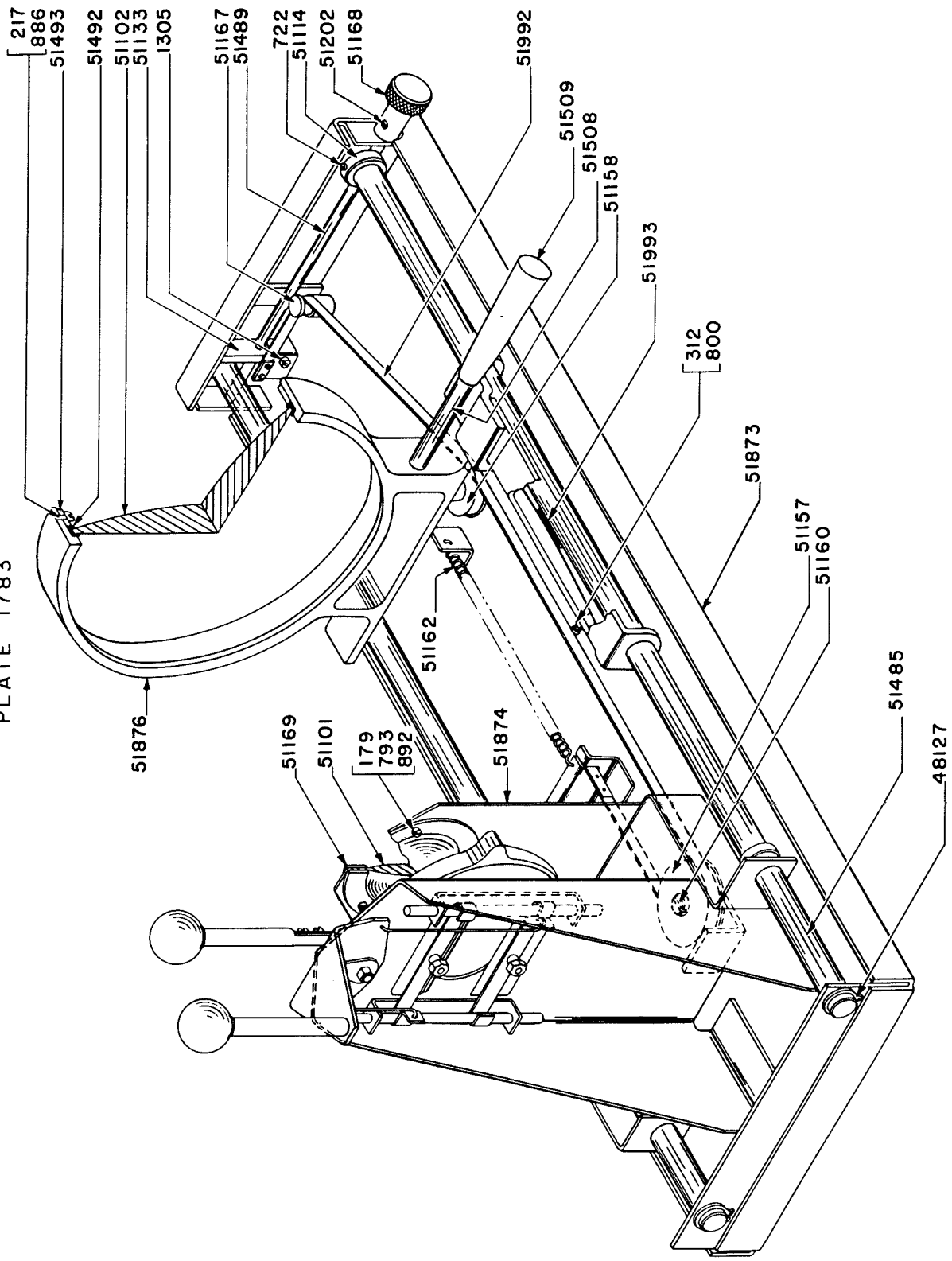
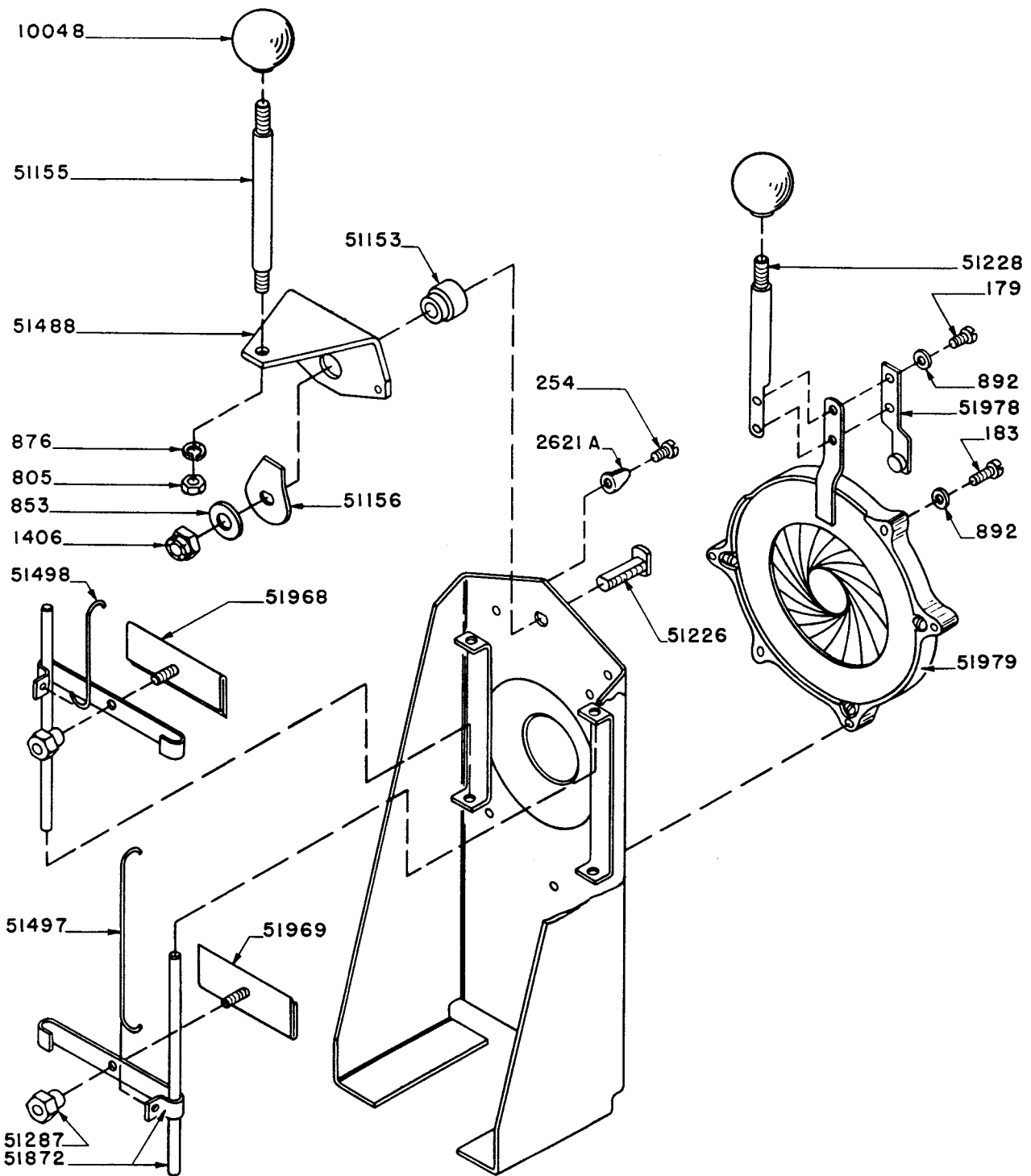

Plate 1783

PLATE 1396



179	Screw, 6-32 x 1/4" Fill. Hd.
183	Screw, 6-32 x 1/2" Fill. Hd.
217	Screw, 8-32 x 5/16" Rd. Hd.
254	Screw, 8-32 x 1/4" Fill. Hd.
312	Screw, 10-32 x 3/8" Rd. Hd.
722	Set Screw, #10-32 x 1/4" Oval Pt. Handless
793	Nut, 6-32, Steel
800	Nut - Half, 10-32 Steel
805	Nut, 1/4-20 Hex
853	Washer, 5/16 Flat Steel
876	L'washer, 1/4" Ditto
886	L'washer, #8 Split Ring
892	L'washer, #6 Shakeproof, #1206 Internal
907	Acorn Nut #10-24
1305	Screw, #6-32 x 1/4 Bd. Hd.
1406	Nut 5/16-18 Flexloc
2621A	Clip - Stop for Iris Handle
10048	Knob
19028-A	Handle - Large Lens Carriage
45180	Slide Rod - Lens Carriage
48127	Retaining Ring - #5100-56
51101	Lens - Small
51102	Lens - Large
51114	Stop Collar
51133	Lens Focus Adjusting Block
51153	Spacer Bushing - Masking Blade
51155	Handle for Masking Blade
51156	Friction Plate, Masking Blade
51157	Pulley, Large
51158	Pulley, Small
51160	Pulley Stud
51162	Tension Spring, Focus Adjusting
51167	Stud, Lens Focusing
51168	Adjusting Knob, Focus
51169	Retaining Ring, Small Lens
51202	Set Screw Focus Adjusting Knob
51226	Stud, Masking Blades
51228	Handle Extension, Iris
51287	Retaining Nut, Masking Blade
51486	Handle, Large Lens
51488	Masking Blade Handle Bracket
51489	Adjusting Screw - Focus
51492	Rubber Edge Mtg.
51493	Ring, Large Lens Carriage
51497	Masking Blade Pull Rod (lower)
51498	Masking Blade Pull Rod (upper)
51872	Slide Assembly - Masking Blade
51874	Small Lens Carriage Assy.

51876 Large Lens Carriage - Welded Assy.  
51968 Masking Blade Assy. (upper)  
51969 Masking Blade Assy. (lower)  
51978 Spring, Iris Friction Pad  
51979 Iris  
51992 Focus Adjusting Ribbon Assembly  
51993 Brake Tension Spring Assy. (lens carriage)

PLATE 765

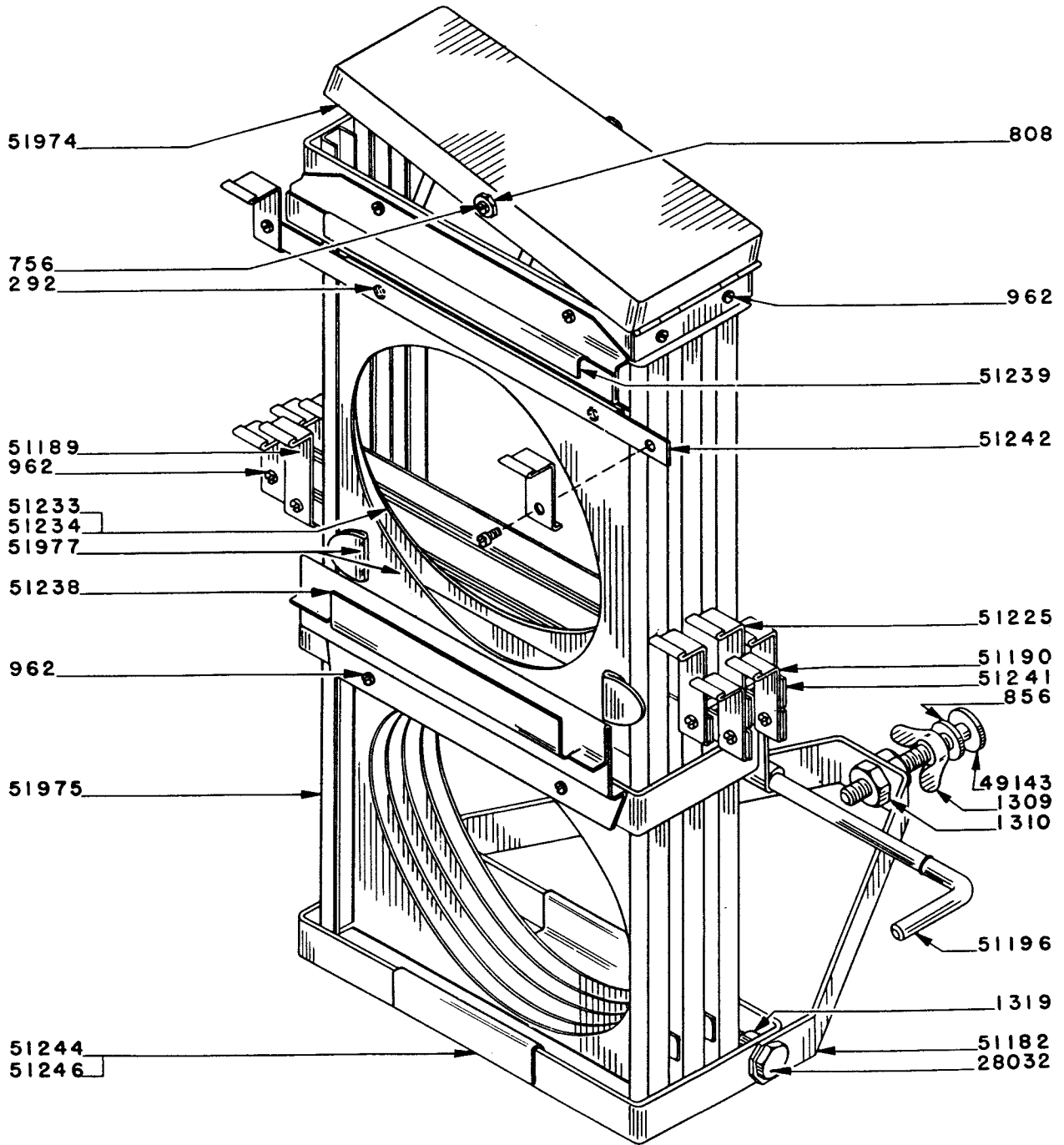

292	Screw #8-32 x 1/8" Fil. Hd.
756	Set Screw 5/16-18 x 3/4" Full Dog Pt.
808	Nut 5/16-18 Hex. Half Nut
856	Washer 1/2" S. A. E. Std.
962	Screw #8-32 x 3/16" Bind. Hd.
1309	Wing Nut 1/2-13
1310	Nut 1/2-13 Hex Half Nut
1319	Nut 3/8-16 "Dualock"
28032	Screw 3/8-16 Special Hd.
49143	Adjustable Bolt
51182	Brace
51189	Finger Lift Handle - Long (R. H. )
51190	Finger Lift Handle - Short
51195	Retaining Lugs (U. V. Lens) (See also #51240)
51196	Hinge Rod
51198	Magnet
51199	Armature - Magnet
51200	Cradle - Magnet
51201	Retaining Strip - Magnet
51225	Finger Lift - Long (L. H. )
51233	Color Filter Holder ✓
51234	Retainer - Color Filter (See #51977 Holder Cage for #51233 & #51234)
51238	Lower Track - U. V. Lens Holder
51239	Upper Track - U. V. Lens Holder
51240	Ultra Violet Lens Holder (See #51195 for Lugs)
51241	Filter Lift Rod - Long
51242	Filter Lift Rod - Short
51244	Stop Plate - Color Frame Cage
51246	Rubber Bumper
51972	Cover Ass'y. - Complete with Magnet
51974	Cover and Latch Ass'y.
51975	Boomerang Frame Ass'y.
51977	Color Filter Cage
51983	Light Shield Ass'y. (Rear of Boomerang)

Serial Number of equipment must be given when ordering parts, or in any reference to the units involved.

Additional color filters may be obtained from any local theatre supply agency.