

# Film-Tech

The information contained in this Adobe Acrobat pdf file is provided at your own risk and good judgment.

These manuals are designed to facilitate the exchange of information related to cinema projection and film handling, with no warranties nor obligations from the authors, for qualified field service engineers.

If you are not a qualified technician, please make no adjustments to anything you may read about in these Adobe manual downloads.

[www.film-tech.com](http://www.film-tech.com)

# Proper Grounding of Equipment

(For non-EC countries only)

In the past it was assumed that if the units were mounted in the same rack that they would be bonded together by way of the rack rails to the mounting ears. The paint used on professional products has gotten much better in the last few years and this assumption is generally no longer true. To ensure a good ground connection between units in the rack and therefore a quiet system with no hum or noise it is highly recommended installing at least one star washer for every piece of equipment. Insulating nylon or plastic washers on the rack screws should not be used with the star washer. See figure below:

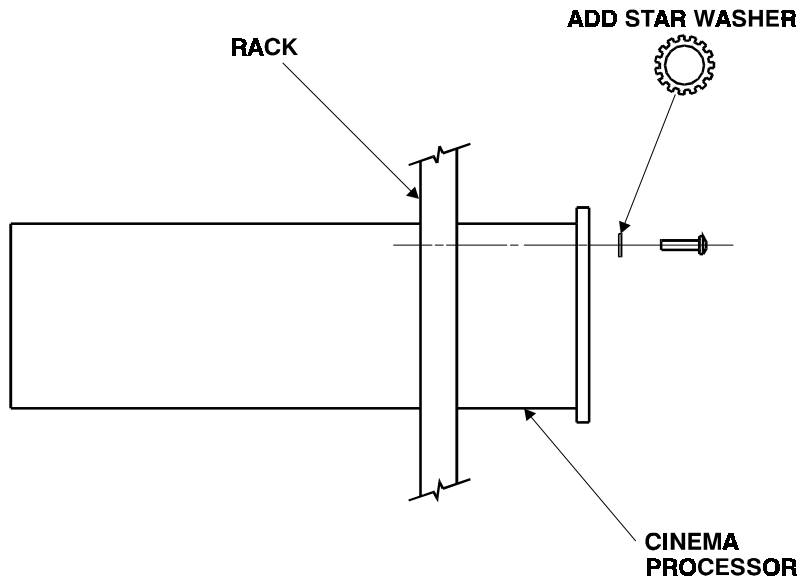

To optimize the grounding of the system you must add a jumper between signal ground of the CP45 and the chassis. See figure below:

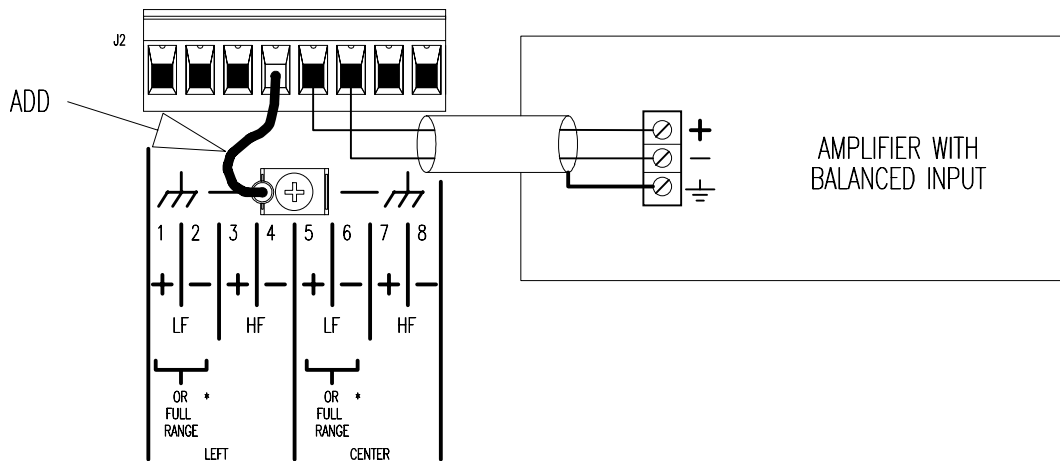

**Connections of Ground jumper and Amplifier**

Most projectors sold in North America come with the new reverse scan LED analog soundhead readers installed. In addition, many existing projectors are being upgraded to include this superior method of playing back SVA soundtracks. The output of the solar cell from this system is at a somewhat lower level than a normal incandescent exciter lamp solar cell. In order to provide the correct signal level for the cinema processor a small preamp board is needed and is mounted in the soundhead.

Since this is an active circuit it must have its signal ground connected to the cinema processor ground for correct operation. Failure to connect the board ground to the cinema processor can result in a noisy optical system or no sound at all. In some instances the signal ground from the board has been connected to the ground of the projector; this method should be avoided as it is not the best way to make this connection. The preferred way is to connect the shield at both ends of the signal path. See figure below:

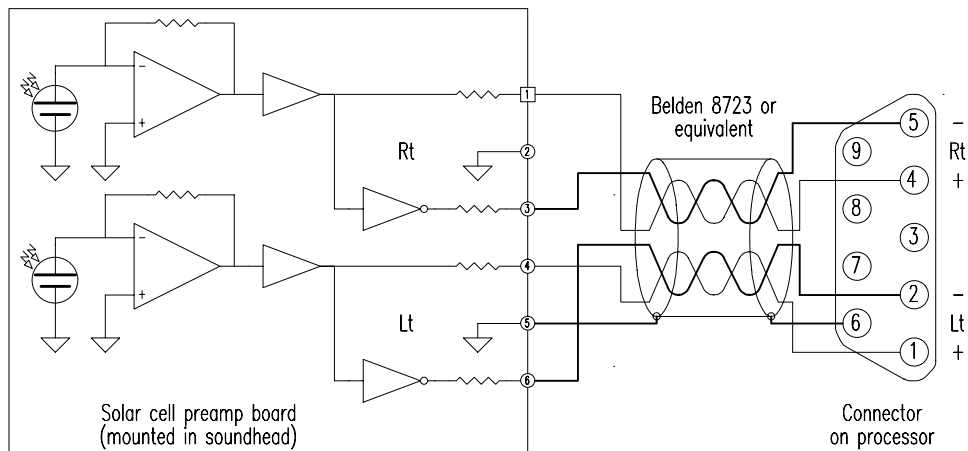
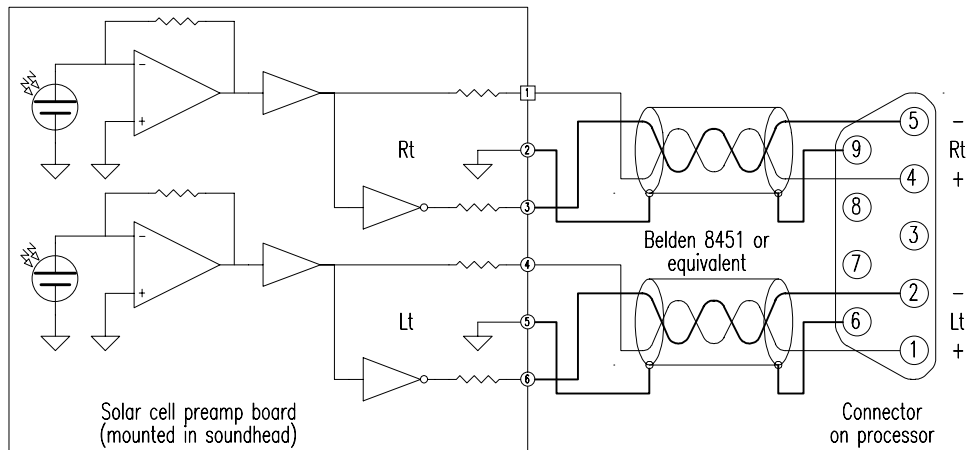

**Proper connection of Reverse Scan LED Readers to Cinema Processor**